

Medium voltage products

# DS1

## Diode-based transient-free capacitor switch

Power and productivity  
for a better world™



# Compensation of reactive power DS1 the future of switches

Compensation of reactive power is required in different parts of the network to ensure stability, increase capacity and reduce power losses thanks to higher power factor.

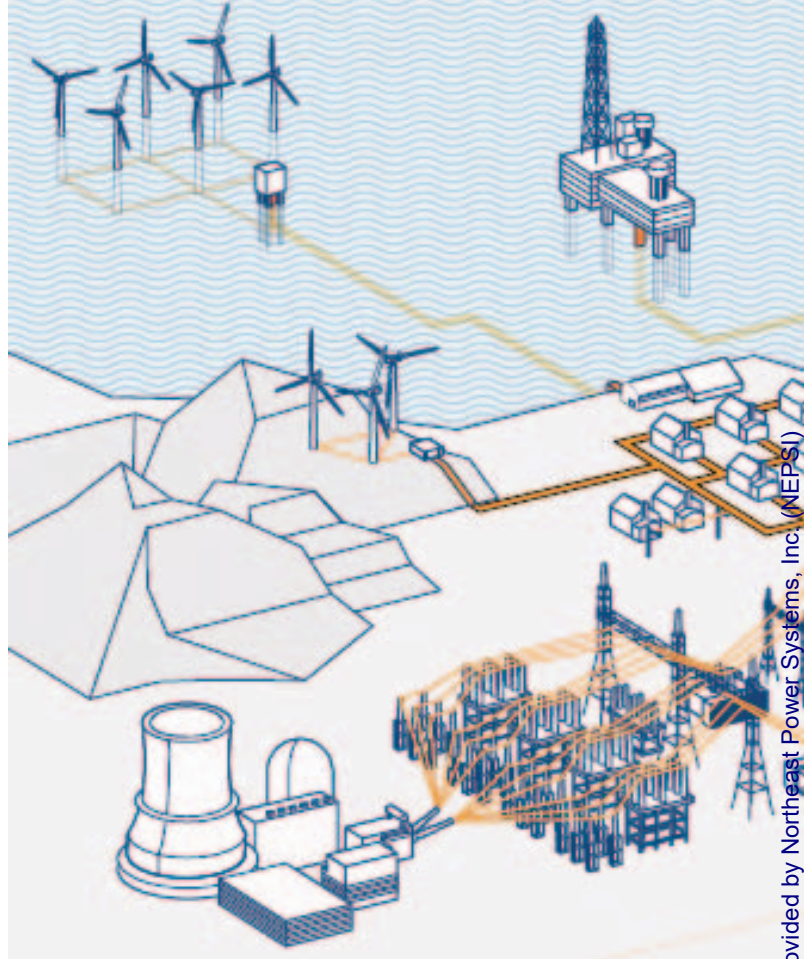

Provided by Northeast Power Systems, Inc. (NEPSI)

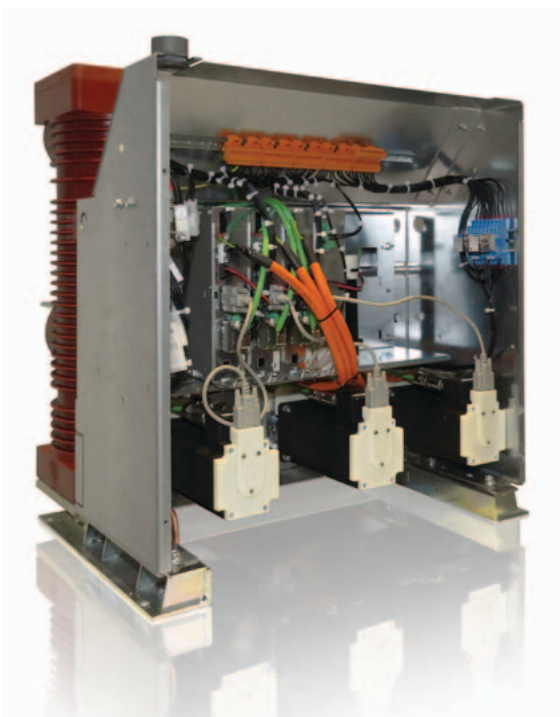

DS1 is the first synchronous switch isolated in dry air specifically devised and designed for capacitor banks.

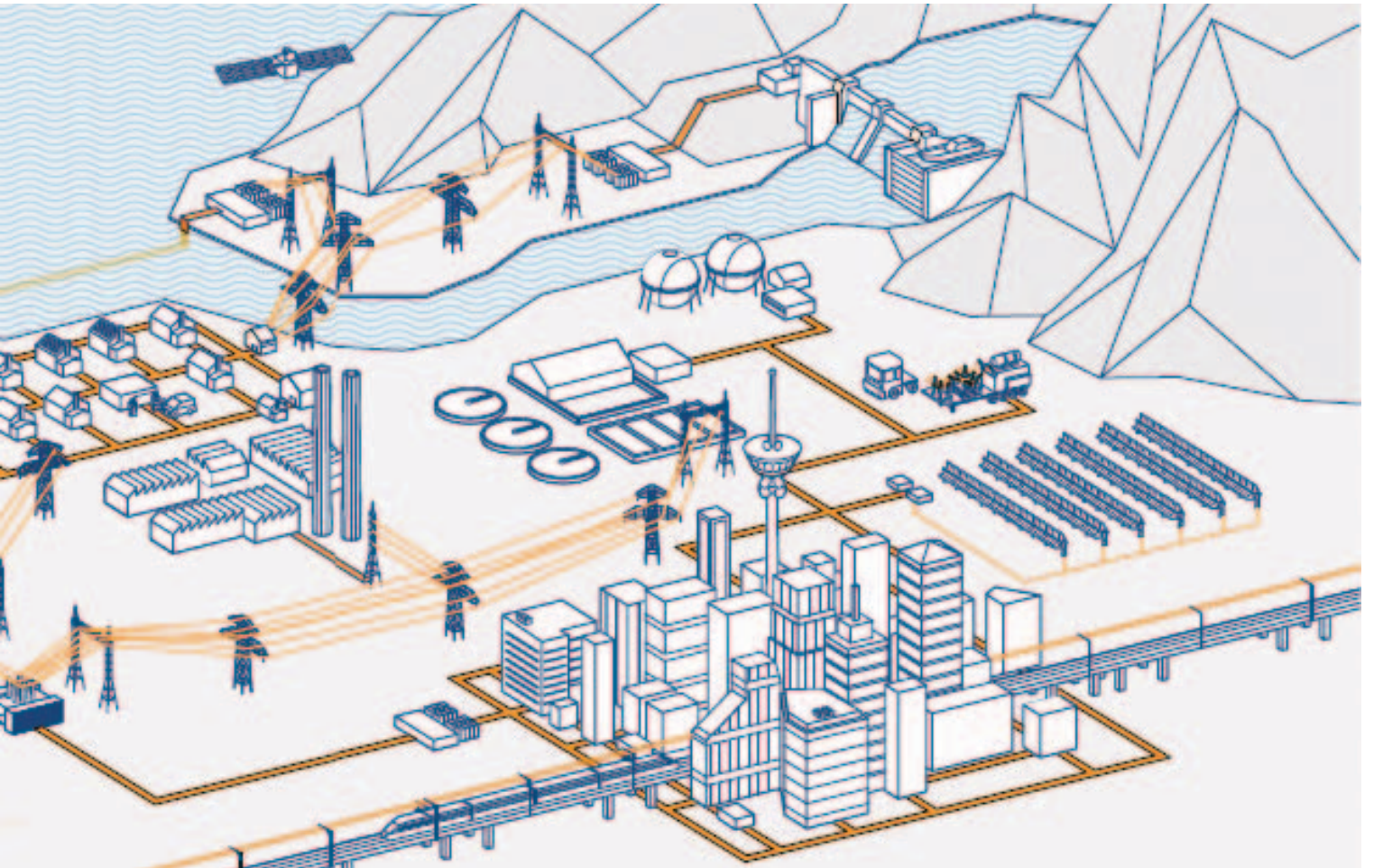

The perfect combination, regulated by the electronic control unit, between the semiconductors and synchronism with the network allows to increase reliability and efficiency and prolongs the life of components.

# A new operational concept

## Event-less closing

DS1 is able to carry out closing operations on capacitor banks without any transient of current, voltage, frequency or the possibility of prestrike.

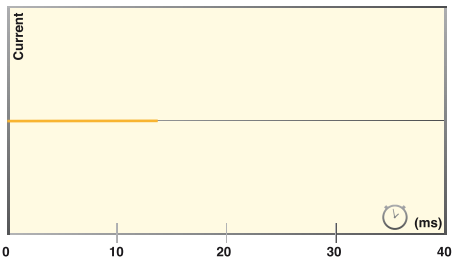
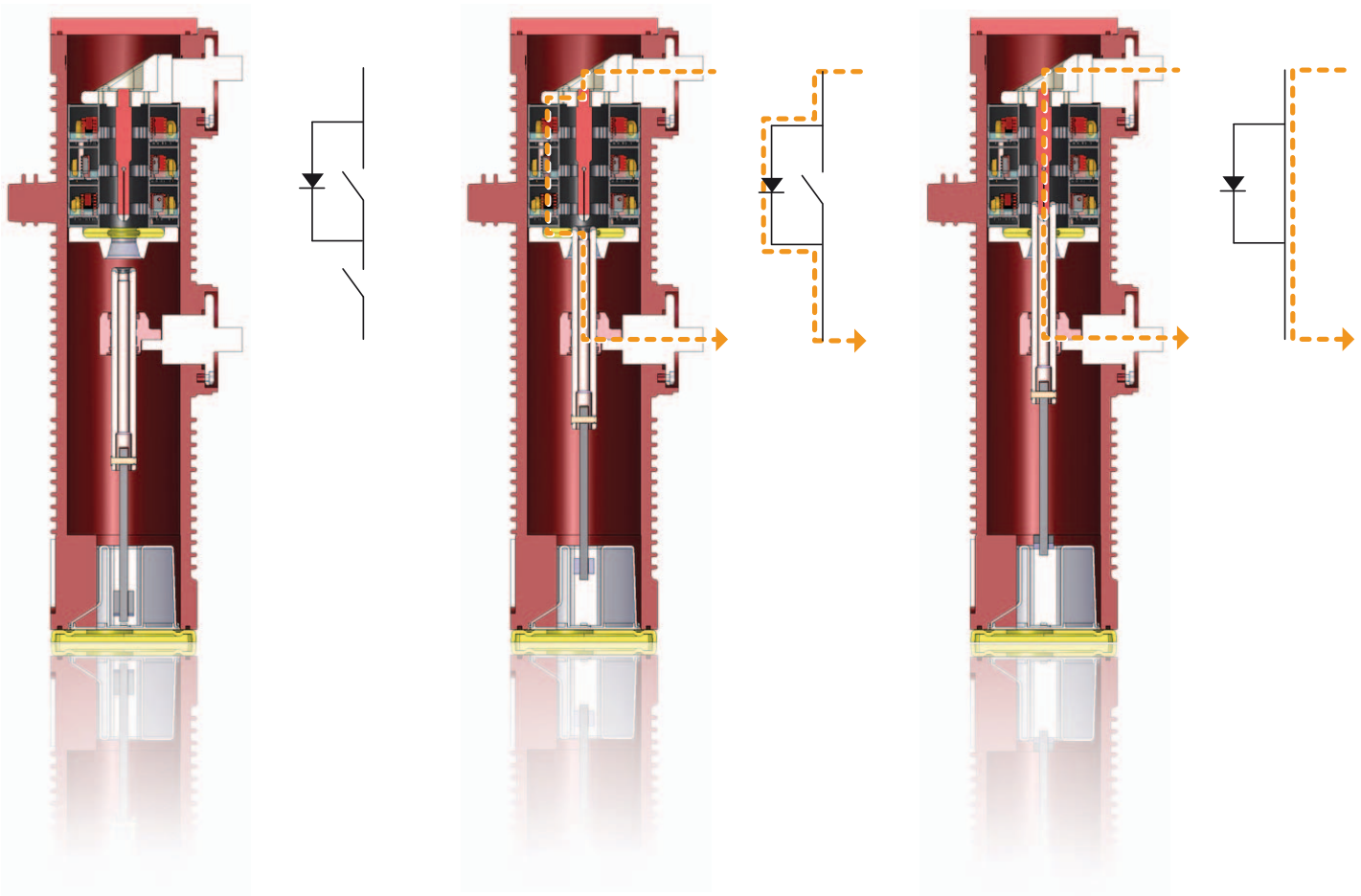

Switch in open position, capacitor bank is disconnected and isolated from the distribution network.

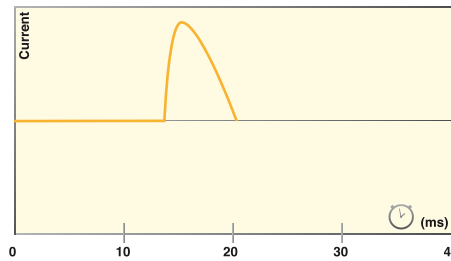

The moving contact connects the semiconductor which naturally energizes the capacitor bank.

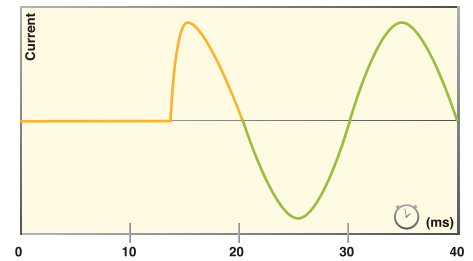

After a quarter of a cycle, the moving contact closes the switch allowing conduction without power losses.

# Event-less opening

DS1 is able to carry out opening operations on capacitor banks without any overvoltage or the possibility of restrike.

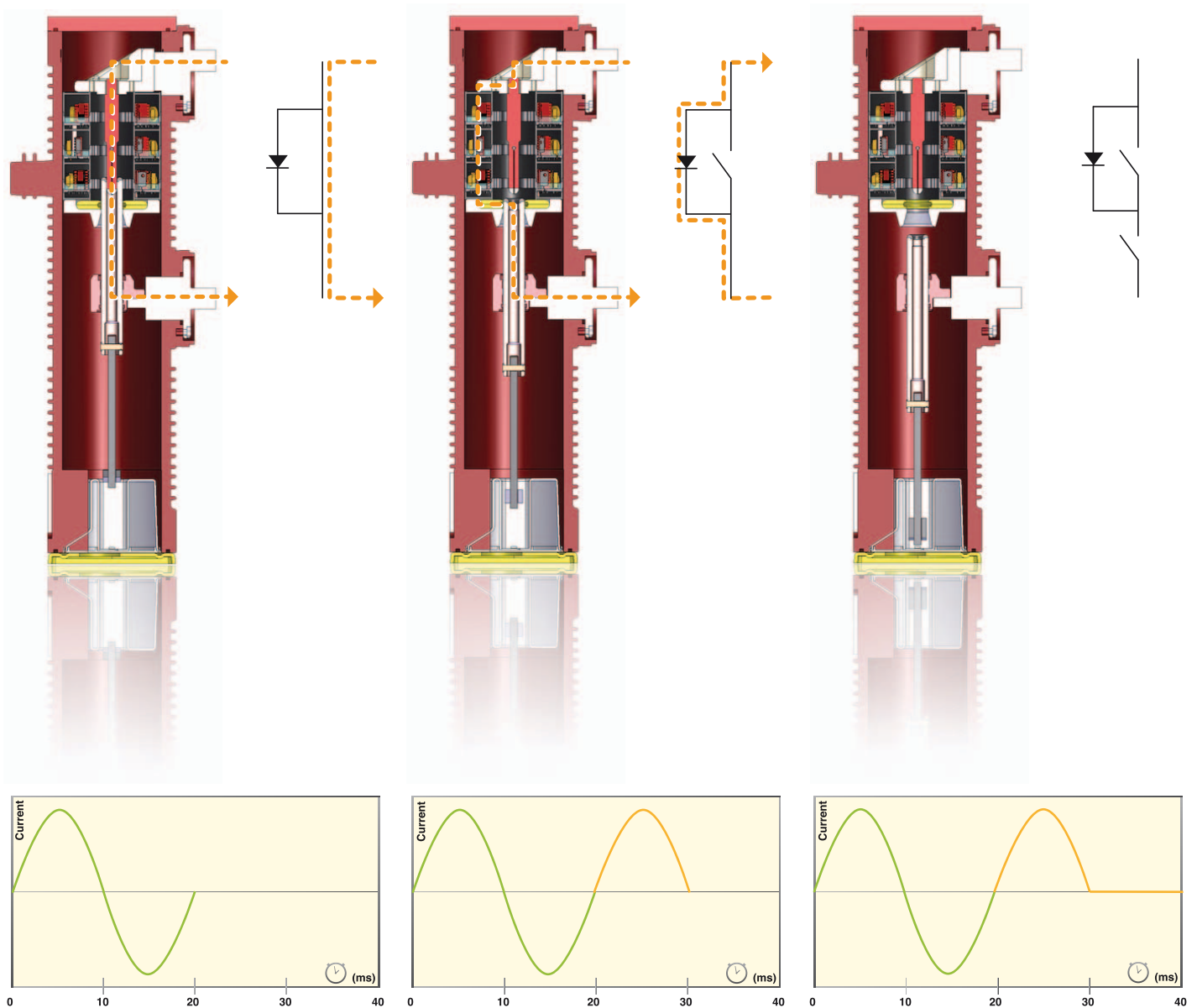

Switch in close position, capacitor bank is connected to the distribution network.

The moving contact connects the semiconductor which allows current conduction.

Half a cycle later, the moving contact disconnects the semiconductor and thus the capacitor bank.

# Powering your compensated network

## Efficiency

DS1 allows capacitor banks to be operated safely and frequently even in back-to-back, allowing more precise tracking of the reactive power to be compensated.

This translates into maximization of the network capacity and installation productivity, as well as a reduction in power losses and CO<sub>2</sub> emissions.

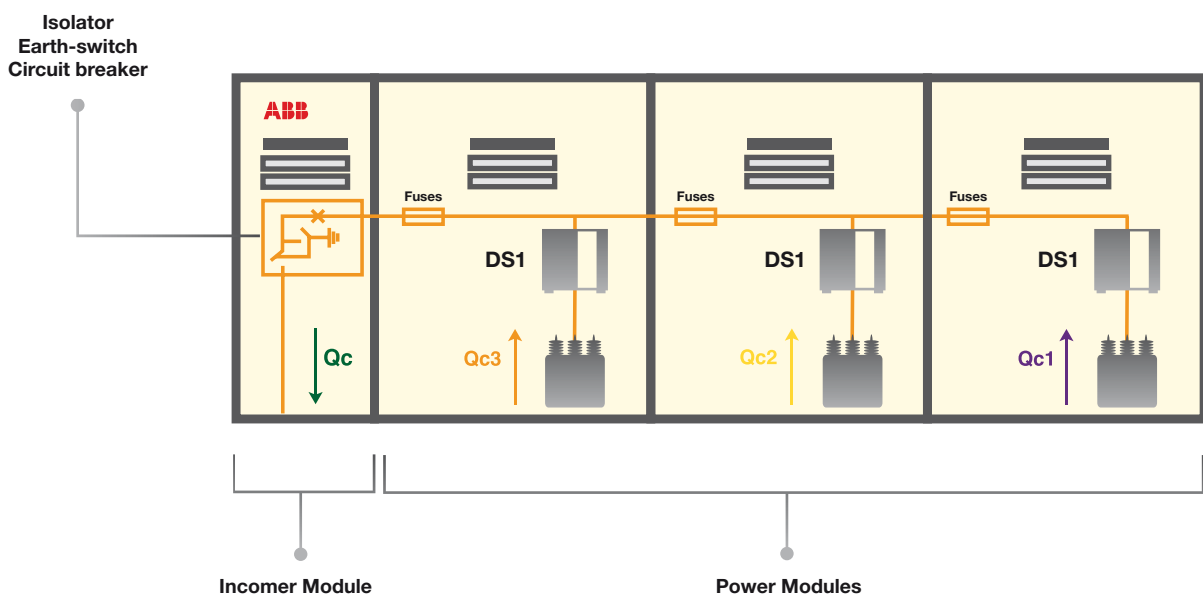
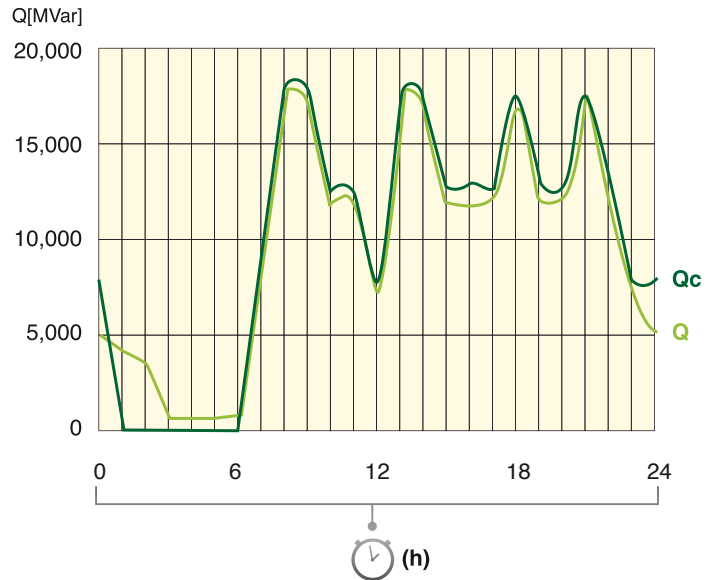

## Reliability

DS1 is monitored by system diagnostics and Micro Motion Control which regularly checks the kinematic mechanism parameters of the DS1 through micro-movements. This translates into safer operations thus avoiding unpredicted outages.

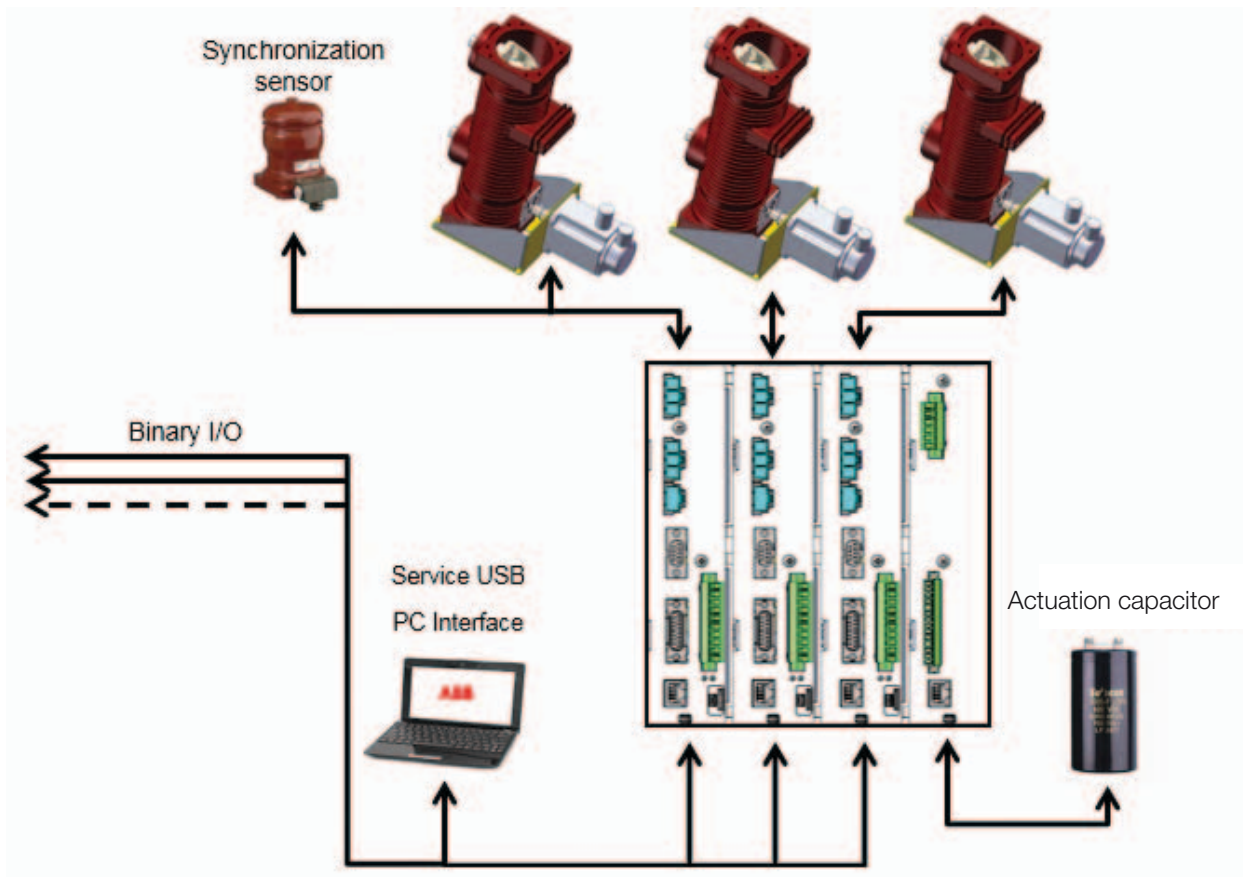

Flexible innovation  
Quick and easy installation

DS1 has a similar layout with respect to ABB indoor circuit breakers.

This means that installation is quick and easy and apparatus can be replaced without the need to redesign the panels or the fixed parts. Furthermore, its interface includes binary inputs and outputs, meaning it can be fully configured and adapted to any network.

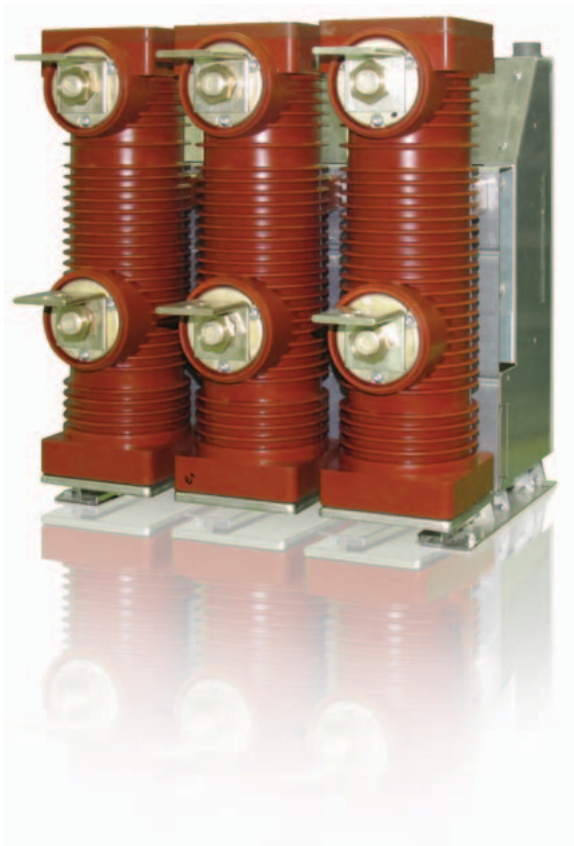



# Space-saving innovation

## Compact design

Thanks to its compact design, DS1 reduces the space required inside the panel.

Its ability to carry out operations without transients also avoids the use of additional components inside the panel, such as inrush reactors.

Only one voltage sensor is required for synchronism.

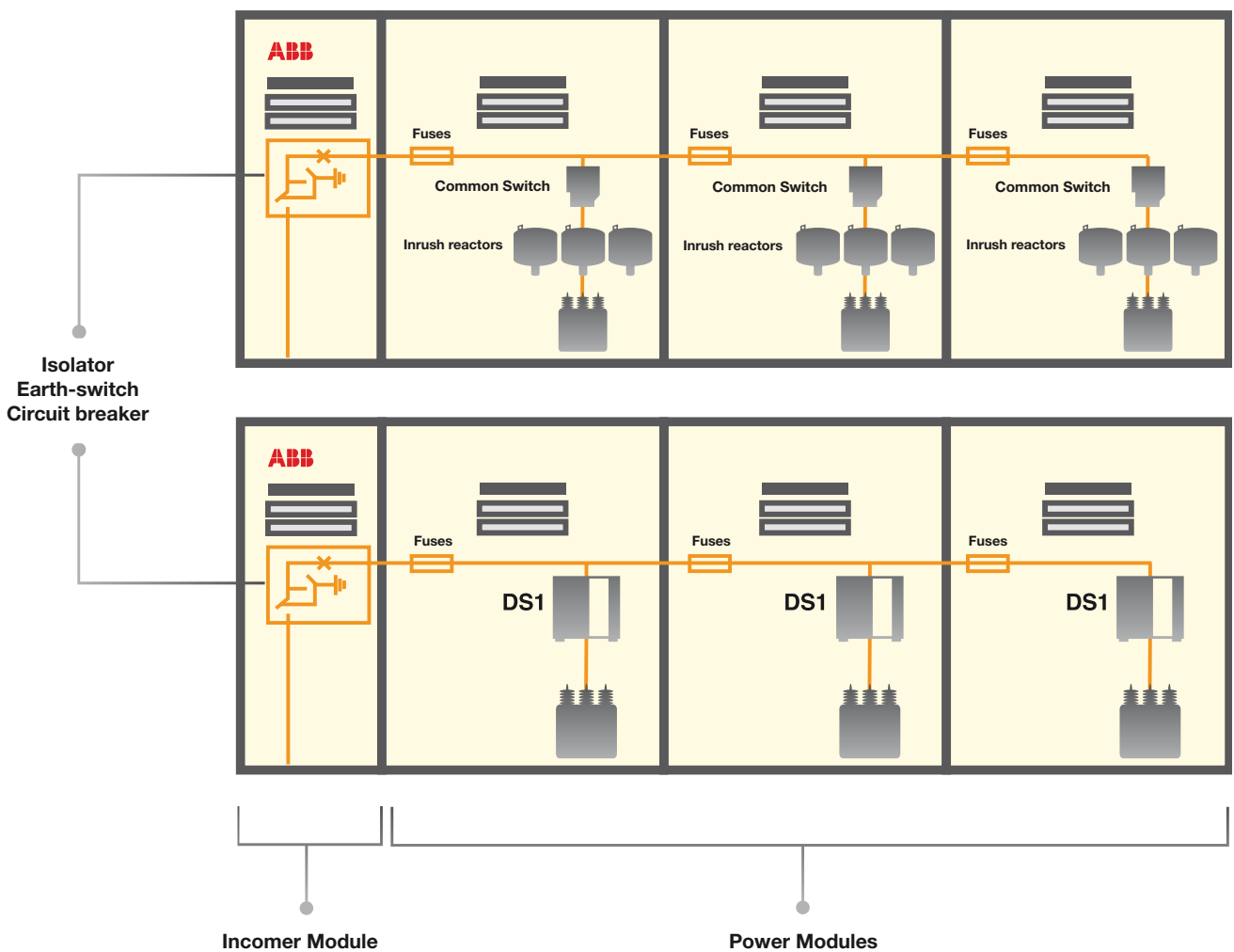

# Integrated system

## Mechanical and electronic synergy

DS1 was developed from a combination of powerful electronics and high precision mechanics, and represents a completely innovative switch concept able to ensure network reliability, stability and efficiency never seen before.

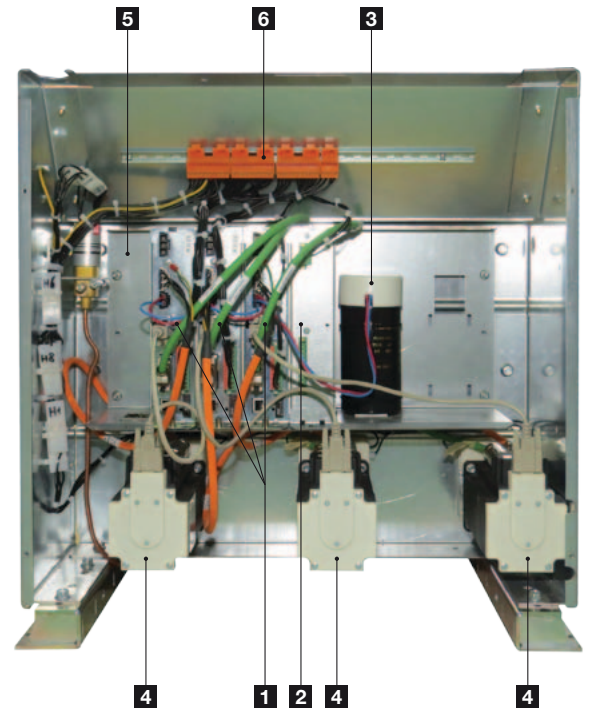
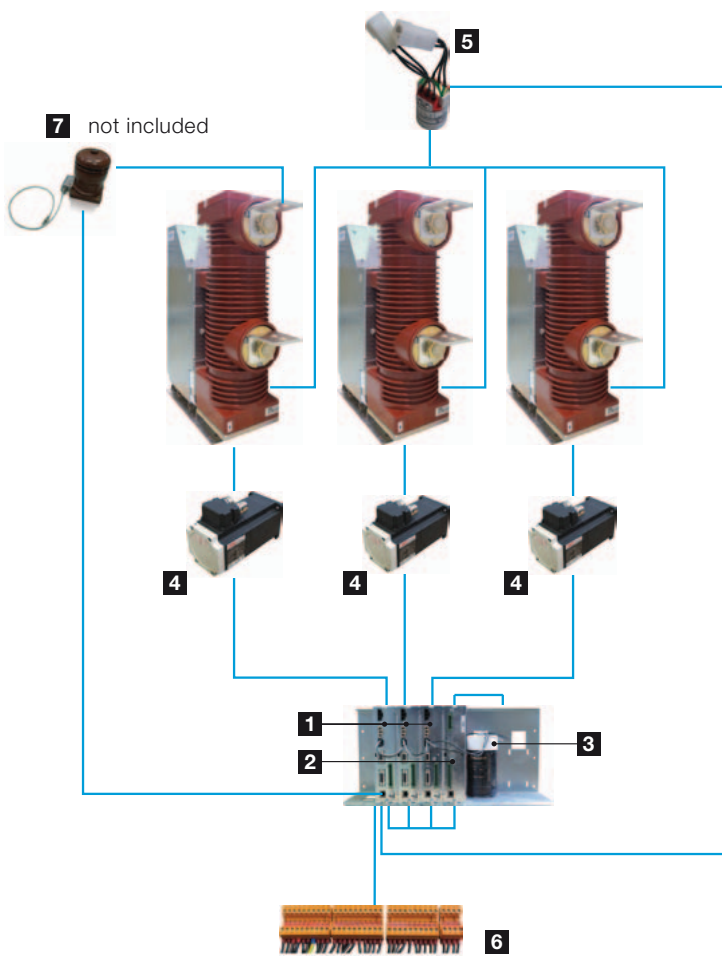

1. Independent servo motors
2. Control unit for each phase:
  - a. Synchronization
  - b. Actuation
  - c. System diagnostics
  - d. Micro Motion Control
3. Dry air pressure sensor
4. DS1 status signals multiplication relay (on request)
5. Operation capacitor
6. Power supply unit

# Technical data

## Classification and ratings

Electrical characteristics		DS1 50	DS1 60
Rated frequency	Hz	50	60
Rated voltage	kV	17.5	15
Rated current	A	630	600
Withstand voltage			
– phase to phase and phase to earth	kV	38 <sup>(1)</sup>	38 <sup>(1)</sup>
– across the insulating distance	kV	45	45
Impulse withstand (BIL)			
– phase to phase and phase to earth	kV	95	95
– across the insulating distance	kV	110	110
Short-time current (time)	kA (s)	20 (0.5)	20 (0.5)
Short-time peak current	kAp	52	52
Other characteristics			
Mechanical operations	CO	50.000	
Maximum overall dimensions		H [mm]	655
		W [mm]	618
		D [mm]	561
		P [mm]	210
Weight	kg	130	
Working temperature range	°C	-15 ... +55	
Maximum installation altitude	mslm	1.000	
Rated dry air absolute pressure	MPa	0.470	

<sup>(1)</sup> Contact ABB for 42 kV version

# Contacts

## **ABB S.p.A.**

### **Power Products Division Unità Operativa Sace-MV**

Via Friuli, 4

I-24044 Dalmine

Tel: +39 035 6952 111

Fax: +39 035 6952 874

E-mail: [info.mv@it.abb.com](mailto:info.mv@it.abb.com)

## **ABB AG**

### **Calor Emag Medium Voltage Products**

Oberhausener Strasse 33      Petzower Strasse 8

D-40472 Ratingen              D-14542 Glindow

Phone: +49(0)2102/12-1230

Fax: +49(0)2102/12-1916

E-mail: [powertech@de.abb.com](mailto:powertech@de.abb.com)

**[www.abb.com](http://www.abb.com)**

The data and illustrations are not binding.

We reserve the right to make changes without notice in the course of technical development of the product.

© Copyright 2015 ABB.  
All rights reserved.