



# SEL-751A Feeder Protection Relay

## Major Features and Benefits

The SEL-751A Feeder Protection Relay provides an exceptional combination of protection, monitoring, control, and communication in an industrial package.

- ▶ **Standard Protection Features.** Protect lines and equipment with phase, negative-sequence, residual-ground, and neutral-ground overcurrent elements. Implement load shedding and other control schemes with current-based over- and underfrequency and breaker failure protection for one three-pole breaker.
- ▶ **Optional Arc-Flash Protection.** Use the SEL-751A with optional four-channel fiber-optic arc-flash detector inputs and protection elements. Settable arc-flash phase and neutral overcurrent elements combined with arc-flash light detection elements provide secure, reliable, and fast acting arc-flash event protection.
- ▶ **Optional Protection Features.** Use the SEL-751A with one of the voltage input options to provide over- and underfrequency, rate-of-change of frequency, fast rate-of-change of frequency (for Aurora vulnerability mitigation), measured residual current input CT, over- and undervoltage, synchronism-check, dc station battery monitor, arc-flash, power elements, and demand metering elements.
- ▶ **Operator Controls and Reclosing.** Easy tripping and closing of the breaker with four programmable front-panel pushbuttons. Implement remote and local control functions, and selectively reclose with synchronism and voltage checks (optional).
- ▶ **Relay and Logic Settings Software.** ACSELERATOR QuickSet<sup>®</sup> SEL-5030 Software reduces engineering costs for relay settings and logic programming. Tools in ACSELERATOR QuickSet make it easy to develop SELOGIC<sup>®</sup> control equations.
- ▶ **Metering and Monitoring.** Use built-in metering functions to eliminate separately mounted metering devices. Analyze Sequential Events Recorder (SER) reports and oscillographic event reports for rapid commissioning, testing, and post-fault diagnostics. Unsolicited SER protocol allows station-wide collection of binary SER messages. The arc-flash detection option provides light metering and event reports for commissioning and arc-flash event capture for analysis.
- ▶ **Wye or Delta Voltage Inputs.** Optional voltage inputs allow for either wye-connected, open-delta-connected, or single voltage inputs to the relay.
- ▶ **Additional Standard Features.** The SEL-751A also includes Modbus<sup>®</sup> RTU, Event Messenger support, MIRRORING BITS<sup>®</sup> communications, load profile, breaker wear monitoring, support for 12 external RTDs (SEL-2600), IRIG-B input, advanced SELOGIC, and IEEE C37.118-compliant synchrophasor protocol.
- ▶ **Optional Features.** Select from a wide offering of optional features, including IEC 61850, DNP3 serial and LAN/WAN, Modbus TCP/IP, Simple Network Time Protocol (SNTP), 10 internal RTDs, expanded digital/analog I/O, voltage inputs, arc-flash fiber-optic inputs, additional EIA-232 or EIA-485 communication ports, fiber-optic serial port, single or dual, copper-wire or fiber-optic Ethernet ports, and configurable labels.



# Overview

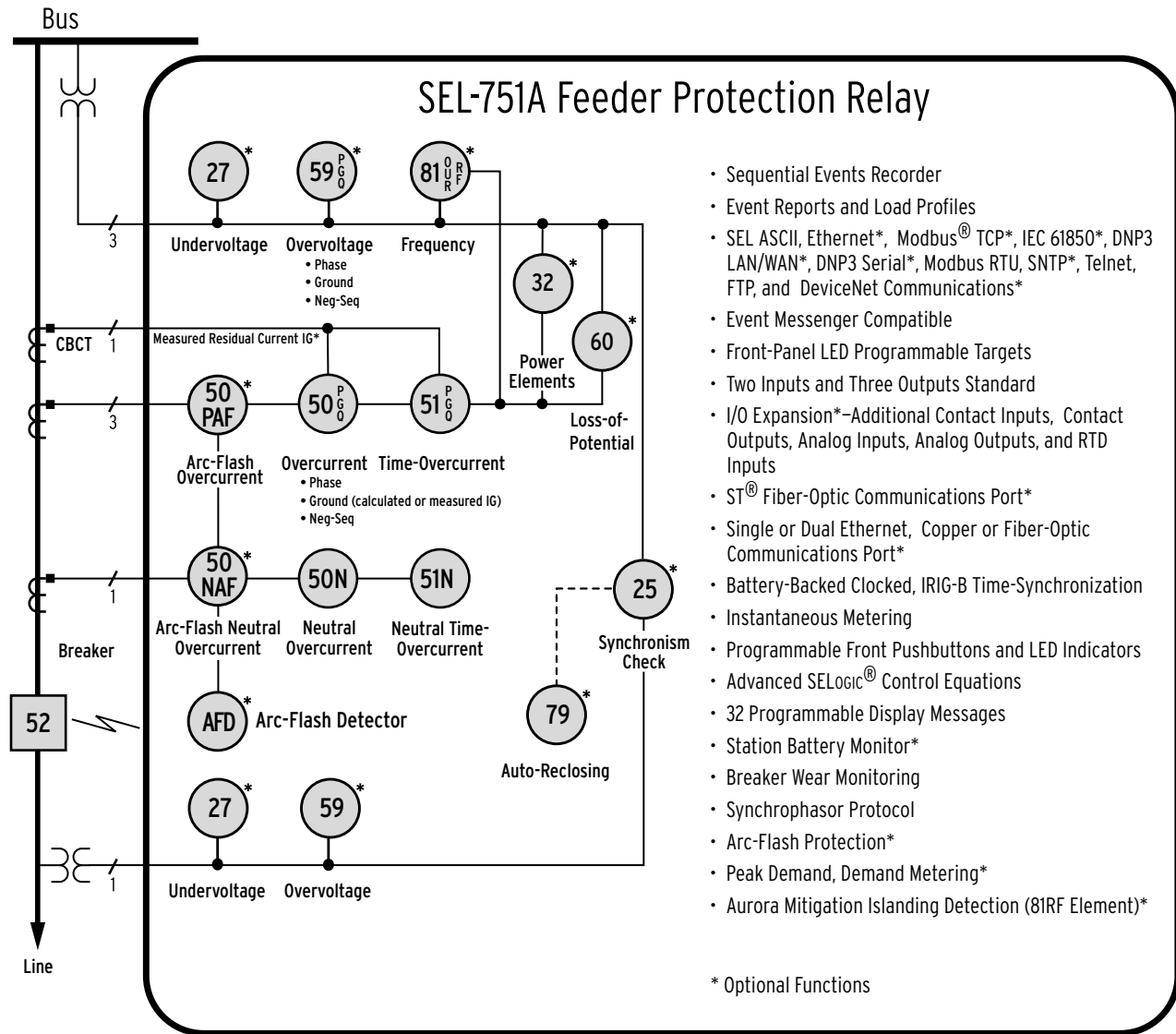

Figure 1 Functional Diagram

Provided by Northeast Power Systems, Inc.  
[www.nepsi.com](http://www.nepsi.com)

## Protection Features

The SEL-751A includes a robust set of phase, negative-sequence, residual, and neutral overcurrent elements. Each element type has four levels of instantaneous protection. Each element type has two time-overcurrent elements (except negative-sequence, which has one time-overcurrent element). *Table 1* lists the curves available in the SEL-751A.

The SEL-751A has two reset characteristic choices for each time-overcurrent element. One choice resets the elements if current drops below pickup for at least one cycle. The other choice emulates electromechanical induction disc elements, where the reset time depends on

the time dial setting, the percentage of disc travel, and the amount of current.

**Table 1 Time-Overcurrent Curves**

US	IEC
Moderately Inverse	Standard Inverse
Inverse	Very Inverse
Very Inverse	Extremely Inverse
Extremely Inverse	Long-Time Inverse
Short-Time Inverse	Short-Time Inverse

## Overcurrent Elements for Phase Fault Detection

Phase and negative-sequence overcurrent elements detect phase faults. Negative-sequence current elements ignore three-phase load to provide more sensitive coverage of phase-to-phase faults. Phase overcurrent elements detect three-phase faults, which do not have significant negative-sequence quantities.

## Overcurrent Elements for Ground Fault Detection

Calculated residual current or optional measured residual current (IG), neutral (IN), and negative-sequence overcurrent elements detect ground faults. In addition to the 1 A/5 A neutral CT, the SEL-751A offers optional high-sensitive neutral element with 50 mA or 2.5 mA nominal current rating.

## Wye or Open-Delta Voltages

Wye-connected (four-wire) voltage or open-delta-connected (three-wire) voltage can be applied to three-phase voltage inputs VA, VB, VC, and N, as shown in *Figure 2*. You only need to make a global setting (DELTA\_Y = wye or DELTA\_Y = delta) and an external wiring change—no internal relay hardware changes or adjustments are required. Thus, a single SEL-751A model meets all your distribution protection needs, regardless of available three-phase voltage.

In addition, the SEL-751A supports single voltage input. For customers with a single PT input, the SEL-751A will assume balanced voltage input for all protection and metering functions.

## Loss-of-Potential Logic

The SEL-751A includes loss-of-potential (LOP) logic that detects one, two, or three blown potential fuses. This patented LOP logic is unique because it does not require settings and is universally applicable. The LOP feature allows the blocking of protection elements to add security during fuse failure.

## Synchronism Check

When you order the 5 AVI voltage option card, single-phase voltage (phase-to-neutral or phase-to-phase) is connected to voltage input VS/NS for synchronism check across a circuit breaker (or hot/dead line check). You can use synchronism-check voltage to coordinate reclosing with the optional recloser control.

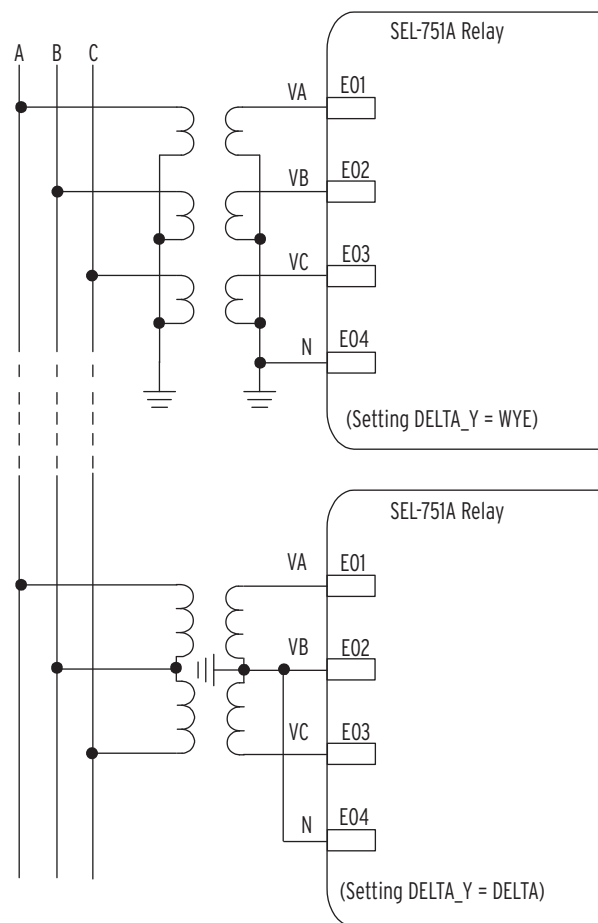

**Figure 2** Connect Wye or Open-Delta Voltage to SEL-751A Three-Phase Voltage Inputs

## Voltage and Frequency Elements for Extra Protection and Control

### Over- and Undervoltage Elements

Phase-to-ground, phase-to-phase, negative-sequence, and residual overvoltage (59) and phase-to-ground or phase-to-phase undervoltage (27) elements in the SEL-751A create the following protection and control schemes:

- ▶ Trip/alarm or event report triggers for over- and undervoltage conditions.
- ▶ Undervoltage (27) load shedding scheme (having both 27 and 81U load shedding schemes allows detection of system MVAR- and MW-deficient conditions).

### Over- and Underfrequency Protection

Six levels of secure overfrequency (81O) or underfrequency (81U) elements detect true frequency disturbances. Use the independently time-delayed output of these elements to shed load or trip local generation. The SEL-751A makes frequency measurements with the voltage input (if available) and switches automatically to current input when voltages are not available.

Implement an internal multistage frequency trip/restore scheme at each breaker location using the multiple over- and underfrequency levels. This method avoids the cost of wiring a complicated trip and control scheme from a separate frequency relay.

## Rate-of-Change of Frequency Protection (Optional)

Four independent rate-of-change of frequency elements are provided with individual time delays for use when frequency changes occur, for example, when there is a sudden imbalance between generation and load. They call for control action or switching action such as network decoupling or load shedding. Each element includes logic to detect either increasing or decreasing frequency and above or below nominal frequency.

## Fast Rate-of-Change-of-Frequency Protection for Aurora Vulnerability Mitigation (Optional)

The fast rate-of-change of frequency protection, 81RF, provides a faster response compared to frequency (81) and rate-of-change of frequency (81R) elements. The fast operating speed makes the 81RF element suitable for detecting islanding conditions. The element uses a characteristic (see *Figure 3*) based on the frequency deviation from nominal frequency ( $\Delta f = \text{FREQ} - \text{FNOM}$ ) and the rate-of-change of frequency (DF3C) to detect islanding conditions. A time window of three cycles is used to calculate the value of DF3C. Under steady state conditions, the operating point is close to the origin. During islanding conditions, the operating point enters Trip Region 1 or Trip Region 2 of the characteristic, depending on the acceleration or deceleration of the islanded system. (81RFDFP in Hz) and (81RFRP in Hz/sec) are the settings used to configure the characteristic.

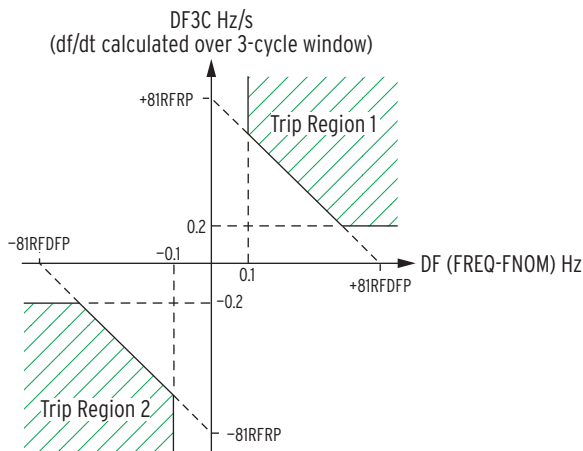

**Figure 3 81RF Characteristic**

## Power Element Protection

The SEL-751A with optional voltage inputs provides two power elements for detecting real (Watts) or reactive (VARs) positive or negative power flow levels for the feeder application. Each power element has a definite-time delay setting.

## Arc-Flash Protection

An arcing short circuit or ground fault in low or medium voltage switchgear can cause very serious equipment damage and personal injury. They can also cause prolonged and expensive downtime.

The best way to minimize the impact of an arc-flash event is to reduce the detection and circuit breaker tripping times. Conventional protection may need several cycles to detect the resulting overcurrent fault and trip the breaker. In some cases, there may not be sufficient current to detect an overcurrent fault. Tripping may be delayed hundreds of milliseconds for sensitivity and selectivity reasons in some applications.

The arc-flash detection-based (AFD) protection can act on the circuit breaker in a few milliseconds (2–5 ms). This fast response can limit the arc-flash energy thus preventing injury to personnel and limiting or eliminating equipment damage.

The arc-flash protection option in the SEL-751A relay adds four-channel fiber-optic AFD inputs and protection elements. Each channel has a fiber-optic receiver and an LED-sourced fiber-optic transmitter that continuously self-tests and monitors the optical circuit to detect and alarm for any malfunction.

There are two types of applications supported by the SEL-751A.

## Point Sensor Application

The arc is detected by transmitting the arc-flash light captured by the optical diffuser (located appropriately in the switchgear) over a 1000  $\mu\text{m}$  plastic fiber-optic cable to the optical detector in the relay. The relay performs sensor loopback tests on the optical system using an LED-based transmitter to transmit light pulses at regular intervals to the point sensor assembly (over a second fiber-optic cable). If the relay optical receiver does not detect this light, the relay declares a malfunction and alarms. *Figure 4* (top) shows a diagram for the point sensor application.

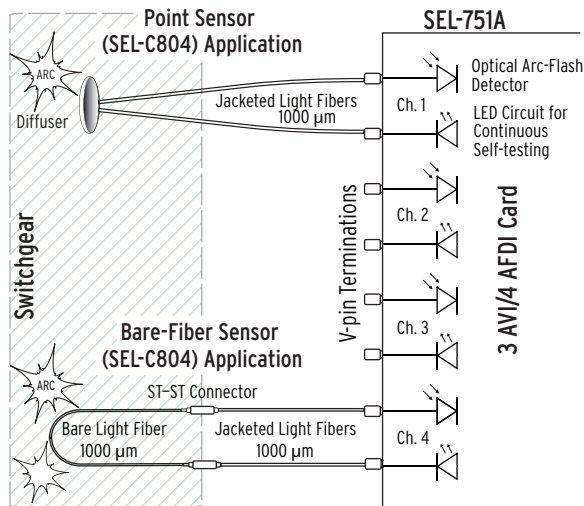

**Figure 4 SEL-751A Arc-Flash Detection System**

### Bare-Fiber Sensor Application

A second option for AFD uses a bare 1000  $\mu\text{m}$  plastic fiber-optic cable located in the switchgear equipment. One end of the fiber is connected to the optical detector in

### Additional Ordering Options

You can order the following options for any SEL-751A model (see the Model Option Table for details).

- ▶ Single or dual, copper or fiber-optic Ethernet port(s), Modbus TCP, SNTCP, DNP3 serial and DNP3 LAN/WAN, FTP, Telnet
- ▶ IEC 61850
- ▶ DeviceNet
- ▶ EIA-232 or EIA-485 communications
- ▶ Fiber-optic serial port (ST only)
- ▶ Additional EIA-232 or EIA-485 port
- ▶ Analog I/O (4 AI/4 AO, 8 AI)

the relay and the other end is connected to the LED transmitter in the relay. The LED transmitter injects periodic light pulses into the fiber as a sensor loopback test to verify the integrity of the loop. The relay detects and alarms for any malfunction. *Figure 4* (bottom) shows a diagram for the bare-fiber sensor application.

The SEL-751A AFD system provides four channels per relay that can be configured for the point sensor or the bare-fiber sensor applications. The optional fast hybrid outputs (high speed and high current) of the relay provide fast-acting trip outputs to the circuit breaker (less than 50  $\mu\text{s}$ ). The fast breaker tripping can avoid serious damage or personal injury in case of an arc-flash event. The relay also provides light metering and light event capture to aid in setting the relay and capturing the arc-flash event for records and analysis.

Settable arc-flash phase and neutral overcurrent elements are combined with arc-flash light detection elements to provide secure, reliable, and fast acting arc-flash event protection.

- ▶ Digital I/O (4 DI/4 DO, 8 DI, 3 DI/4 DO/1 AO, 4 DI/3 DO)
- ▶ Voltage options including monitoring package inputs (three-phase voltage input, synchronism-check input, station battery monitor input), advanced monitoring and protection, four-channel fiber-optic AFD inputs and protection, and measured residual current CT input. See *Table 2*.
- ▶ 10 RTDs
- ▶ Conformal coating for chemically harsh and high moisture environments

**Table 2 Voltage Input Options (Sheet 1 of 2)**

Voltage Input Options	Option (71)	Option (72)	Option (73)	Option (74)	Option (75/76)
	SELECT 3AVI <sup>a</sup>	SELECT 5AVI <sup>b</sup>	SELECT 5AVI <sup>c</sup>	SELECT 3 AVI/4 AFDI <sup>d</sup>	SELECT 5 AVI/1 ACI <sup>e</sup>
Under- and overvoltage elements (27, 59)	x	x	x	x	x
Voltage based frequency measurement and tracking	x	x	x	x	x
Over-, underfrequency elements (81)	x	x	x	x	x
Power factor elements (55)	x	x	x	x	x
Loss of potential element (60LOP)	x	x	x	x	x
Real, reactive, apparent power, and power factor metering	x	x	x	x	x
Energy metering	x	x	x	x	x
Synchronism-check elements including under- and over-voltage elements (25, 27S, 59S)		x	x		x
Station dc battery voltage monitor		x	x		x
Demand and peak demand metering			x	x	x
Residual overvoltage element (59G)			x	x	x
Negative-sequence overvoltage element (59Q)			x	x	x



**Table 2 Voltage Input Options (Sheet 2 of 2)**

Voltage Input Options	Option (71)	Option (72)	Option (73)	Option (74)	Option (75/76)
	SELECT 3AVI <sup>a</sup>	SELECT 5AVI <sup>b</sup>	SELECT 5AVI <sup>c</sup>	SELECT 3 AVI/4 AFDI <sup>d</sup>	SELECT 5 AVI/1 ACI <sup>e</sup>
Rate-of-change of frequency element (81R)			X	X	X
Fast rate-of-change of frequency element (81RF), Aurora mitigation			X	X	X
Power elements (32)			X	X	X
4-channel optical arc-flash sensor inputs with continuous self-testing (AFD)				X	
Arc-flash protection elements (50PAF, 50NAF)				X	
Residual current (IG) CT-based residual overcurrent elements (50G, 51G)					X

<sup>a</sup> Voltage Options.

<sup>b</sup> With Monitoring Package.

<sup>c</sup> With Monitoring and Advanced Metering and Protection Packages.

<sup>d</sup> With 4-channel Arc-Flash Detector Inputs and Protection.

<sup>e</sup> SELECT 5AVI/1 ACI With Residual Ground CT Input.

## Operator Controls and Reclosing

### Operator Controls Eliminate Traditional Panel Control Switches

Four conveniently sized operator controls are located on the relay front panel (see *Figure 5*). You can set the SER to track operator controls. You can also change operator control functions using SELOGIC control equations.

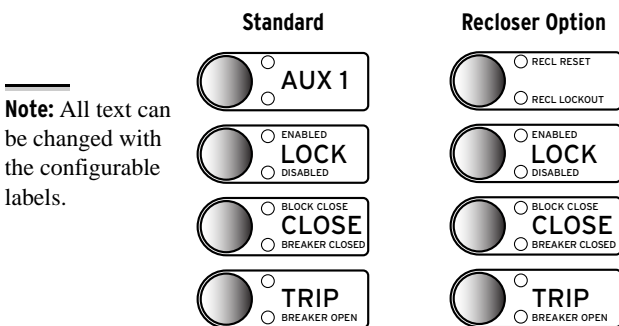

**Figure 5 Operator Controls for Standard and Optional Reclosing Models**

The following operator control descriptions are for factory-set logic.

In the standard SEL-751A, users can program the top operator control and its corresponding two LEDs. When the SEL-751A is ordered with optional reclosing, the two LEDs are programmed to give the status of the reclosing. The two LEDs, RECL RESET and RECL LOCKOUT, indicate whether the recloser is in the Reset or Lockout state.

The {LOCK} operator control blocks selected functions. Press it for at least three seconds to engage or disengage the lock function. While locked in position, the following operator controls cannot change state if pressed: {TRIP} and {CLOSE}.

Use the {CLOSE} and {TRIP} operator controls to close and open the connected circuit breaker. Program with intentional time delays to support operational requirements for breaker-mounted relays. This allows the operator to press the {CLOSE} or {TRIP} pushbutton, then move to an alternate location before the breaker command is executed.

### Programmable Autoreclosing

When ordered with optional reclosing, the SEL-751A can autoreclose a circuit breaker up to four times before lockout. Use SELOGIC control equations to program the SEL-751A to perform the following reclosing functions:

- ▶ Allow closing, e.g., when the load-side line is dead, or when the two systems are in synchronism (optional).
- ▶ Advance the shot counter without tripping, e.g., when another protective relay clears a fault, also known as sequence coordination.
- ▶ Initiate reclosing, e.g., for particular protection trip operations.
- ▶ Drive-to-lockout, e.g., when an optoisolated input is deasserted.
- ▶ Delay reclosing, e.g., after a trip caused by a close-in, high-duty fault.
- ▶ Flexible reclose supervision failure scheme that allows going to lockout or moving to the next available shot.

The reclosing shot counter controls which protective elements are involved in each reclose interval. Applications include fuse- and trip-saving schemes. The front-panel LEDs (Reset and Lockout) track the reclosing state.

## Relay and Logic Settings Software

ACSELERATOR QuickSet Software simplifies settings and provides analysis support for the SEL-751A. With ACSELERATOR QuickSet you have several ways to create and manage relay settings:

- Develop settings off-line with an intelligent settings editor that only allows valid settings.
- Create SELOGIC control equations with a drag-and-drop text editor.
- Configure proper settings using online help.
- Organize settings with the relay database manager.
- Load and retrieve settings using a simple PC communications link.

With ACSELERATOR QuickSet you can verify settings and analyze events; and analyze power system events with the integrated waveform and harmonic analysis tools.

The following features of ACSELERATOR QuickSet can monitor, commission, and test the SEL-751A:

- The PC interface will remotely retrieve power system data.
- The Human-Machine Interface (HMI) will monitor meter data, Relay Word bits, and output contacts status during testing. The control window allows resetting of metering quantities, arc-flash sensor testing and diagnostics, and other control functions.

## Metering and Monitoring

The SEL-751A provides extensive metering capabilities. See *Specifications on page 19* for metering and power measurement accuracies. As shown in *Table 3*, metered quantities include phase voltages and currents; sequence voltages and currents; power, frequency, and energy; and maximum/minimum logging of selected quantities. The relay reports all metered quantities in primary quantities (current in A primary and voltage in V primary).

**Table 3 Metering Capabilities**

Quantities <sup>a</sup>	Description
Currents IA, IB, IC, IN, IG	Input currents, residual ground current ( $IG = 3I_0 = IA + IB + IC$ OR measured IG)
Voltages VA, VB, VC	Wye-connected voltage inputs
Voltages VAB, VBC, VCA	Delta-connected voltage inputs
Voltage VS	Synchronism-check voltage input
Power kW <sub>A,B,C,3P</sub> kVAR <sub>A,B,C,3P</sub> kVA <sub>A,B,C,3P</sub>	Single and three-phase kilowatts, kilovars, and kilovolt-amps
Energy MWh <sub>3P</sub> , MVARh <sub>3P-IN</sub> , MVARh <sub>3P-OUT</sub> , MVAh <sub>3P</sub>	Three-phase megawatt hours, megavar-hours, and megavolt-amp-hours
Power Factor PF <sub>A,B,C,3P</sub>	Single and three-phase power factor (leading or lagging)
Sequence 3I <sub>2</sub> , 3I <sub>0</sub> , 3V <sub>2</sub> , 3V <sub>0</sub>	Negative- and zero-sequence currents and voltages
Frequency, FREQ (Hz)	Instantaneous power system frequency
Voltage VDC	Station battery voltage
Light Intensity (%) LS1-LS4	Arc-flash light inputs in % of full scale

<sup>a</sup> Single-phase power, energy, and power factor quantities are not available when delta-connected PTs are used.

## Load Profile

The SEL-751A features a programmable Load Profile (LDP) recorder that records up to 17 metering quantities into nonvolatile memory at fixed time intervals. The LDP saves several days to several weeks of the most recent data depending on the LDP settings.

## Synchronized Phasor Measurement

Combine the SEL-751A with an SEL IRIG-B time source to measure the system angle in real time with a timing accuracy of  $\pm 10 \mu s$ . Measure instantaneous voltage and current phase angles in real time to improve system operation with synchrophasor information. Replace state measurement, study validation, or track system stability. Use SEL-5077 SYNCHROWAVE<sup>®</sup> Server Software or SEL-5078 SYNCHROWAVE Console Software to view system angles at multiple locations for precise system analysis and system-state measurement (see *Figure 6*).

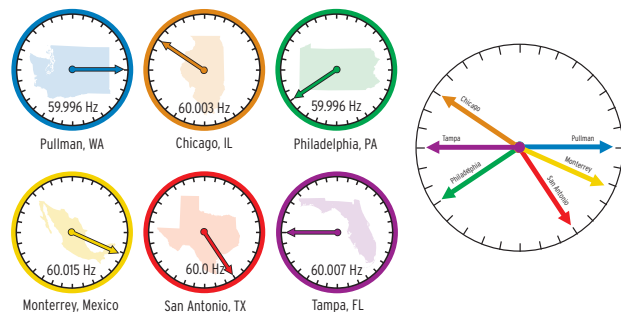

**Figure 6 View of System Angle at Multiple Locations**

## Event Reporting

Event Reports and the SER simplify post-fault analysis and improve understanding of simple and complex protective scheme operations. In response to a user-selected trigger, the voltage, current, frequency, and element status information contained in each event report confirms relay, scheme, and system performance for every fault. Decide how much detail is necessary when you request an event report (e.g., 1/4-cycle or 1/16-cycle resolution, filtered or raw analog data).

The relay stores as many as 19 of the most recent 64-cycle or as many as 77 of the most recent 15-cycle event reports in nonvolatile memory. The relay always appends relay settings to the bottom of each event report.

The following analog data formats are available:

- 1/4-cycle or 1/16-cycle resolution
- Unfiltered or filtered analog
- ASCII or Compressed ASCII

The relay SER feature stores the latest 1024 entries. Use this feature to gain a broad perspective at a glance. An SER entry helps to monitor input/output change-of-state occurrences and element pickup/dropout.

The IRIG-B time-code input synchronizes the SEL-751A time to within  $\pm 1$  ms of the time-source input. A convenient source for this time code is the SEL-2401 Satellite-Synchronized Clock or the SEL-2032, SEL-2030, or SEL-2020 Communications Processor (via Serial Port 2 or 3 on the SEL-751A).

## Substation Battery Monitor

The SEL-751A relays that include the enhanced voltage option with the monitoring package measure and report the substation battery voltage connected to the VBAT terminals. The relay includes two programmable threshold comparators and associated logic for alarm and control. For example, if the battery charger fails, the measured dc falls below a programmable threshold. The SEL-751A alarms to alert operations personnel before the substation battery voltage falls to unacceptable levels. Monitor these thresholds with an SEL communications processor and trigger messages, telephone calls, or other actions.

The measured dc voltage appears in the METER display and the VDC column of the event report. Use the event report column data to see an oscillographic display of the battery voltage. This display shows how much the substation battery voltage drops during trip, close, and other control operations.

## Circuit Breaker Contact Wear Monitor

Circuit breakers experience mechanical and electrical wear every time they operate. Intelligent scheduling of breaker maintenance takes into account manufacturer's published data of contact wear versus interruption levels and operation count. With the breaker manufacturer's maintenance curve as input data, the SEL-751A breaker monitor feature compares this input data to the measured (unfiltered) ac current at the time of trip and the number of close-to-open operations.

Every time the breaker trips, it integrates the measured current information. When the result of this integration exceeds the breaker wear curve threshold (*Figure 7*) the relay alarms via output contact, communications port, or front-panel display. This kind of information allows timely and economical scheduling of breaker maintenance.

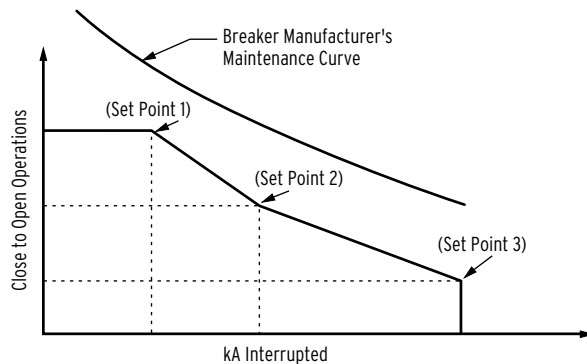

**Figure 7 Breaker Contact Wear Curve and Settings**



# Automation

## Flexible Control Logic and Integration Features

The SEL-751A is equipped with as many as four independently operated serial ports: one EIA-232 port on the front, one EIA-232 or EIA-485 port on the rear, and one fiber-optic port. Additionally, the SEL-751A has one EIA-232 or EIA-485 port option card. Optionally, the relay supports single or dual , copper or fiber-optic Ethernet ports. The relay does not require special communica-

tions software. You can use any system that emulates a standard terminal system. Establish communication by connecting: computers; modems; protocol converters; printers; an SEL-2032, SEL-2030 or SEL-2020 Communications Processor; SCADA serial port; and/or RTUs for local or remote communication. Refer to *Table 4* for a list of communications protocols available in the SEL-751A.

**Table 4 Communications Protocols**

Type	Description
Simple ASCII	Plain language commands for human and simple machine communications. Use for metering, setting, self-test status, event reporting, and other functions.
Compressed ASCII	Comma-delimited ASCII data reports. Allows external devices to obtain relay data in an appropriate format for direct import into spreadsheets and database programs. Data are checksum protected.
Extended Fast Meter and Fast Operate	Binary protocol for machine-to-machine communications. Quickly updates SEL communications processors, RTUs, and other substation devices with metering information, relay element, I/O status, time-tags, open and close commands, and summary event reports. Data are checksum protected. Binary and ASCII protocols operate simultaneously over the same communications lines so control operator metering information is not lost while a technician is transferring an event report.
Fast SER Protocol	Provides SER events to an automated data collection system.
Modbus	Serial- or Ethernet-based Modbus with point remapping. Includes access to metering data, protection elements, contact I/O, targets, SER, relay summary event reports, and setting groups.
DNP3	Serial or Ethernet-based DNP3 protocols. Provides default and mappable DNP3 objects that include access to metering data, protection elements, Relay Word bits, contact I/O, targets, SER, relay summary event reports, and setting group selection.
IEC 61850	Ethernet-based international standard for interoperability between intelligent devices in a substation. Operates remote bits and I/O. Monitors Relay Word bits and analog quantities.
Synchrophasors	IEEE C37.118-compliant synchrophasors for system state, response, and control capabilities.
Event Messenger	The SEL-3010 allows users to receive alerts sent directly to their cell phone. Alerts can be triggered through relay events and can include quantities measured by the relay.
DeviceNet	Allows for connection to a DeviceNet network for access to metering data, protection elements, contact I/O, targets, and setting groups.
SNTP	Ethernet-based protocol that provides time synchronization of the relay.

Apply an SEL communications processor as the hub of a star network, with point-to-point fiber or copper connection between the hub and the SEL-751A (*Figure 8*).

The communications processor supports external communications links including the public switched telephone network for engineering access to dial-out alerts and private line connections of the SCADA system.

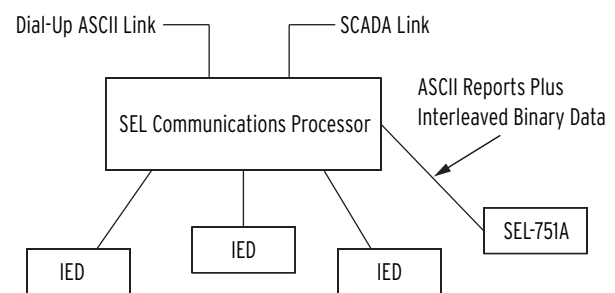

**Figure 8 Example Communication System**

SEL manufactures a variety of standard cables for connecting this and other relays to a variety of external devices. Consult your SEL representative for more information on cable availability.

SEL-751A control logic improves integration in the following ways:

- ▶ Replaces traditional panel control switches. Eliminate traditional panel control switches with 32 local bits. Set, clear, or pulse local bits with the front-panel push-buttons and display. Program the local bits into your control scheme with SELOGIC control equations. Use the local bits to perform functions such as a trip test or a breaker trip/close.
- ▶ Eliminates RTU-to-relay wiring. Eliminate RTU-to-relay wiring with 32 remote bits. Set, clear, or pulse remote bits using serial port commands. Program the remote bits into your control scheme with SELOGIC control equations. Use remote bits for SCADA-type control operations such as trip, close, and settings group selection.
- ▶ Replaces traditional latching relays. Replace up to 32 traditional latching relays for such functions as “remote control enable” with latch bits. Program latch set and latch reset conditions with SELOGIC control equations. Set or reset the nonvolatile latch bits using optoisolated inputs, remote bits, local bits, or any programmable logic condition. The latch bits retain their state when the relay loses power.
- ▶ Replaces traditional indicating panel lights. Replace traditional indicating panel lights with 32 programmable displays. Define custom messages (e.g., *Breaker Open*, *Breaker Closed*) to report power system or relay conditions on the front-panel display. Use Advanced SELOGIC control equations to control which messages the relay displays.
- ▶ Eliminate external timers. Eliminate external timers for custom protection or control schemes with 32 general purpose SELOGIC control equation timers. Each timer has independent time-delay pickup and dropout

settings. Program each timer input with any element you want (e.g., time qualify a current element). Assign the timer output to trip logic, transfer trip communications, or other control scheme logic.

- ▶ Eliminate settings changes. Selectable setting groups make the SEL-751A ideal for applications requiring frequent setting changes and for adapting the protection to changing system conditions.

The relay stores three setting groups. Select the active setting group by optoisolated input, command, or other programmable conditions. Use these setting groups to cover a wide range of protection and control contingencies.

Switching setting groups switches logic and relay element settings. Program groups for different operating conditions, such as feeder paralleling, station maintenance, seasonal operations, emergency contingencies, loading, source changes, and downstream relay setting changes.

## Fast SER Protocol

SEL Fast SER Protocol provides SER events to an automated data collection system. SEL Fast SER Protocol is available on any rear serial port. Devices with embedded processing capability can use these messages to enable and accept unsolicited binary SER messages from SEL-751A relays.

SEL relays and communications processors have two separate data streams that share the same serial port. The normal serial interface consists of ASCII character commands and reports that are intelligible to people using a terminal or terminal emulation package. The binary data streams can interrupt the ASCII data stream to obtain information, and then allow the ASCII data stream to continue. This mechanism allows a single communications channel to be used for ASCII communications (e.g., transmission of a long event report) interleaved with short bursts of binary data to support fast acquisition of metering or SER data.

# Ethernet Network Architectures

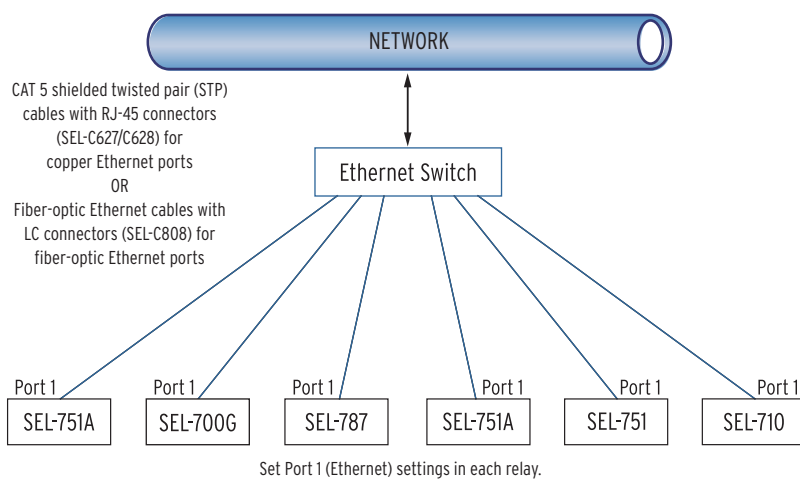

**Figure 9 Simple Ethernet Network Configuration**

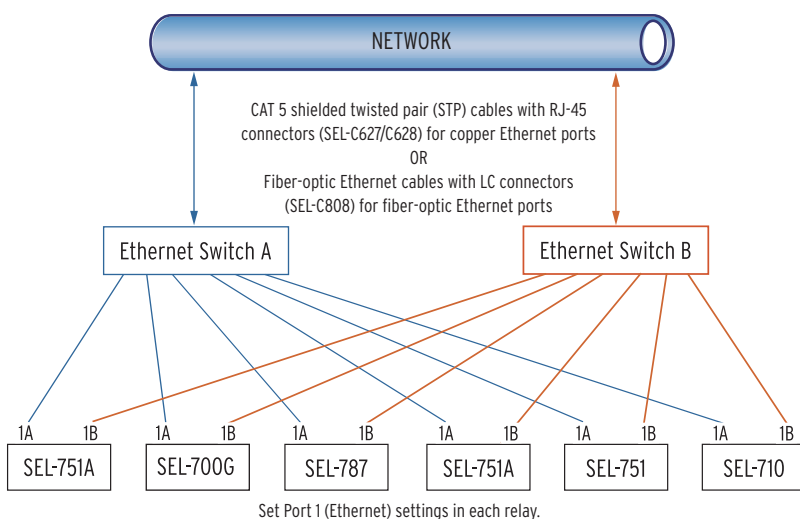

**Figure 10 Simple Ethernet Network Configuration With Dual Redundant Connections (Failover Mode)**

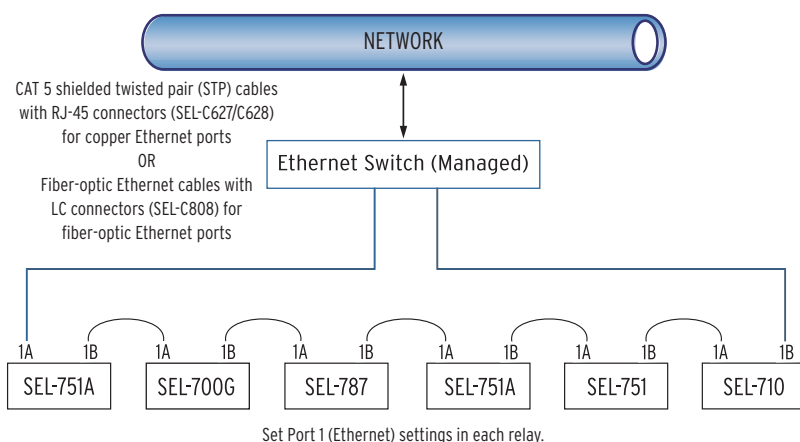

**Figure 11 Simple Ethernet Network Configuration With Ring Structure (Switched Mode)**

Provided by Northeast Power Systems, Inc.  
[www.nepsi.com](http://www.nepsi.com)

## Additional Features

### MIRRORED BITS Relay-to-Relay Communications

The SEL-patented MIRRORED BITS communications technology provides bidirectional relay-to-relay digital communications. MIRRORED BITS can operate independently on up to two EIA-232 rear serial ports and one fiber-optic rear serial port on a single SEL-751A.

This bidirectional digital communication creates eight additional virtual outputs (transmitted MIRRORED BITS) and eight additional virtual inputs (received MIRRORED BITS) for each serial port operating in the MIRRORED BITS mode (see *Figure 12*). Use these MIRRORED BITS to transmit/receive information between upstream relays and a downstream recloser control (e.g., SEL-351R) to enhance coordination and achieve faster tripping for downstream faults. MIRRORED BITS technology also helps reduce total scheme operating time by eliminating the need to assert output contacts to transmit information.

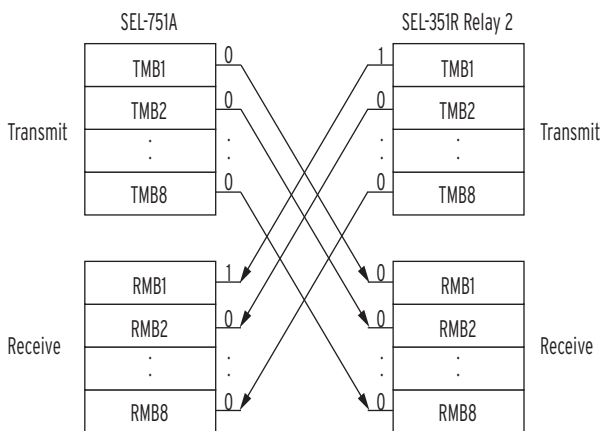

**Figure 12** MIRRORED BITS Transmit and Receive Bits

### Status and Trip Target LEDs

The SEL-751A includes 16 status and trip target LEDs on the front panel. When shipped from the factory, all LEDs are predefined and fixed in settings. You can reprogram these LEDs for specific applications. This combination of targets is explained and shown in *Figure 14*. Some front-panel relabeling of LEDs may be needed if you reprogram them for unique or specific applications—see *Configurable Labels*.

### Event Messenger Points

The SEL-751A, when used with the SEL-3010 Event Messenger, can allow for ASCII-to-voice translation of as many as 32 user-defined messages, along with analog data that has been measured or calculated by the relay. This combination can allow the user to receive voice messages on any phone for alerts to transition of any Relay Word bits in the relay.

Verbal notification of breaker openings, fuse failures, RTD alarms, etc. can now be sent directly to your cell phone through the use of your SEL-751A and SEL-3010 (must be connected to an analog telephone line). In addition, messages can include an analog value such as current, voltage, or power measurements made by the SEL-751A.

### Configurable Labels

Use the optional configurable labels to relabel the operator controls and LEDs (shown in *Figure 14*) to suit the installation requirements. This feature includes preprinted labels (with factory default text), blank label media, and a Microsoft® Word template on CD-ROM. This allows quick, professional-looking labels for the SEL-751A. Labels may also be customized without the use of a PC by writing the new label on the blank stock provided. The ability to customize the control and indication features allows specific utility or industry procedures to be implemented without the need for adhesive labels. All of the figures in this data sheet show the factory default labels of the SEL-751A, including the standard model shown in *Figure 14*.

# Guideform Specification

Feeder protection shall be provided by a microprocessor-based relay equipped with the following protection, monitoring, control, automation, and reporting functions. Self-checking functions shall be included. Specific requirements are as follows.

## Protection and Control

- ▶ Phase, neutral, residual, and negative-sequence over-current elements (50P/50N/50G/50Q)
- ▶ Phase, neutral, residual, and negative-sequence time-overcurrent elements (51P/51N/51G/51Q)
- ▶ Current-based over- and underfrequency (81)
- ▶ Breaker/contact failure
- ▶ Autoreclosing control (79)

Optionally, the relay shall provide the following protection elements.

- ▶ Arc-flash detection and arc-flash overcurrent (50PAF, 50NAF)
- ▶ Over- and undervoltage (59, 59G, 59Q, 27)
- ▶ Power elements (32)
- ▶ Power factor (55)
- ▶ Voltage-based over- and underfrequency (81)
- ▶ Rate-of-change of frequency (81R)
- ▶ Loss-of-potential (60)
- ▶ Synchronism check (25)
- ▶ Measured residual overcurrent (50G/51G)
- ▶ Fast rate-of-change of frequency (81RF) for Aurora mitigation

## Temperature Inputs

Availability of up to 12 RTD inputs in an external module (SEL-2600 with ST option) or 10 RTD inputs with an internal card, which, when included, shall have the following features:

- ▶ Optical fiber transmission of RTD temperatures (using SEL-2600) to relay: range > 1000 m
- ▶ Separately field-selected RTD types: Pt100, Ni100, Ni120, or Cu10
- ▶ Noise immunity (50 Hz and higher) on RTD inputs up to 1.4 V<sub>ac</sub><sub>peak</sub>
- ▶ One contact input (with SEL-2600)

## Automation

- ▶ 32 local control logic points, 32 remote control logic points, 32 latching logic points, 32 counters, 32 math variables, 32 logic variables, and 32 timers
- ▶ SELOGIC control equations with Boolean and math equations capability for logic and control

## Communications/Integration

- ▶ ASCII, Modbus RTU, DeviceNet, Event Messenger, MIRRORED BITS, SNMP, Telnet, FTP, Modbus TCP, DNP3 serial and LAN/WAN, IEEE C37.118 (synchrophasor data), and IEC 61850 protocols
- ▶ One front-panel EIA-232 port and one rear-panel EIA-232 or EIA-485 port, one optional ST fiber-optic serial port, and an optional single or dual, copper or fiber-optic Ethernet port(s)
- ▶ Capability for an additional rear-panel EIA-232 or EIA-485 port
- ▶ Windows<sup>®</sup>-based PC software for setting, report retrieval, metering, HMI, and control.

## Front-Panel Visualization

- ▶ The front panel shall be capable of displaying measured values, calculated values, I/O status, device status, and configuration parameters on a front-panel LCD display.
- ▶ The display shall have a rotating capability to display custom messages and data. Thirty-two display messages shall be provided.
- ▶ The front panel shall also have a minimum of six user-programmable LEDs and four user-programmable pushbutton controls with eight programmable LEDs.



## Monitoring and Reporting

- Load-profile monitoring: Provide periodic snapshot (selectable rate from every 5 to 60 minutes) of up to 17 selectable analog quantities
- Metering: The relay shall include metering capabilities for real-time current, voltage, power, energy qualities, and phase demand and peak demand current and power values. RTD temperature metering, synchrophasor data metering, and minimum/ maximum metering shall also be included. The arc-flash protection shall include light metering.
- Event summaries: Fault type and trip data, including time of tripping
- Event reports: 15-cycle length (up to 77 reports) or 64-cycle length (up to 19 reports) with 4 or 16 samples/cycle resolution
- SER: Up to 1024 time-tagged, most recent input, output, and element transitions
- Data stored in nonvolatile, Flash memory
- Station battery monitor with two levels of detection (monitoring package)
- Breaker wear monitoring
- Event report with arc-flash light input

## Synchronized Phasor Measurements

- The relay shall provide high-accuracy phasor measurements for voltages and currents if an IRIG-B signal is available.
- The relay shall provide a selectable synchrophasor data update rate of 1–10 times per second.

## Hardware

- Operating temperature range of  $-40^{\circ}$  to  $+85^{\circ}\text{C}$
- Power supply input operating voltage range of 24/48 Vdc, 125/250 Vdc, or 120/240 Vac
- Demodulated IRIG-B time-synchronization input capability
- Optional 10 internal RTD inputs or 12 external RTD inputs
- 5 A or 1 A, ac current inputs IA, IB, IC, and IN with optional 2.5 mA or 50 mA sensitive IN input
- Optional 5 A or 1 A ac residual current input IG
- 300 V maximum, 3 ac voltage inputs, synchronism-check voltage input, station battery voltage input, and arc-flash detection (AFD) inputs
- Electromechanical or optional fast hybrid (high-speed, high-current interruption) digital outputs
- Optoisolated digital inputs
- Jumper-selectable current (up to  $\pm 20$  mA range) or voltage (up to  $\pm 10$  V range) analog inputs
- Relay front panel shall meet the requirements of NEMA 12/IP65
- Class 1, Division 2 Hazardous Locations certification

## Service and Support

- Reliability: The vendor shall supply the actual measured Mean Time Between Failures (MTBF) for the device upon request.
- Manufacturer: The device shall be manufactured in the U.S.A.
- Conformal Coating: The device shall have optional conformal coating to protect the circuit boards from harsh environments.
- Warranty: The device shall include a ten-year, no-questions-asked warranty for all material and workmanship defects. In addition, the warranty shall cover accidental, customer-induced damage.

# Wiring Diagrams

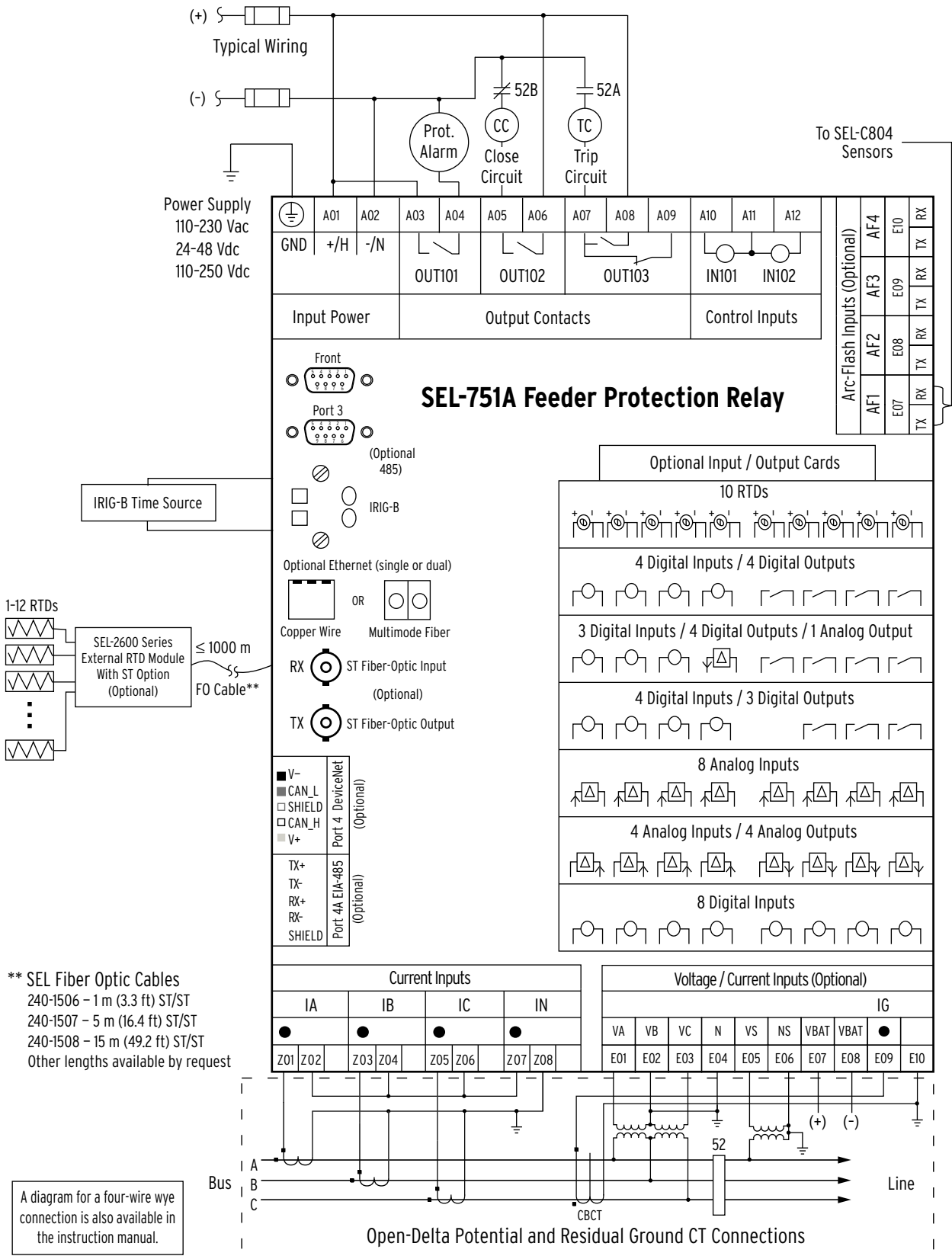

\*\* SEL Fiber Optic Cables  
 240-1506 – 1 m (3.3 ft) ST/ST  
 240-1507 – 5 m (16.4 ft) ST/ST  
 240-1508 – 15 m (49.2 ft) ST/ST  
 Other lengths available by request

A diagram for a four-wire wye connection is also available in the instruction manual.

**Figure 13 Wiring Diagram SEL-751A**

# Panel Diagrams

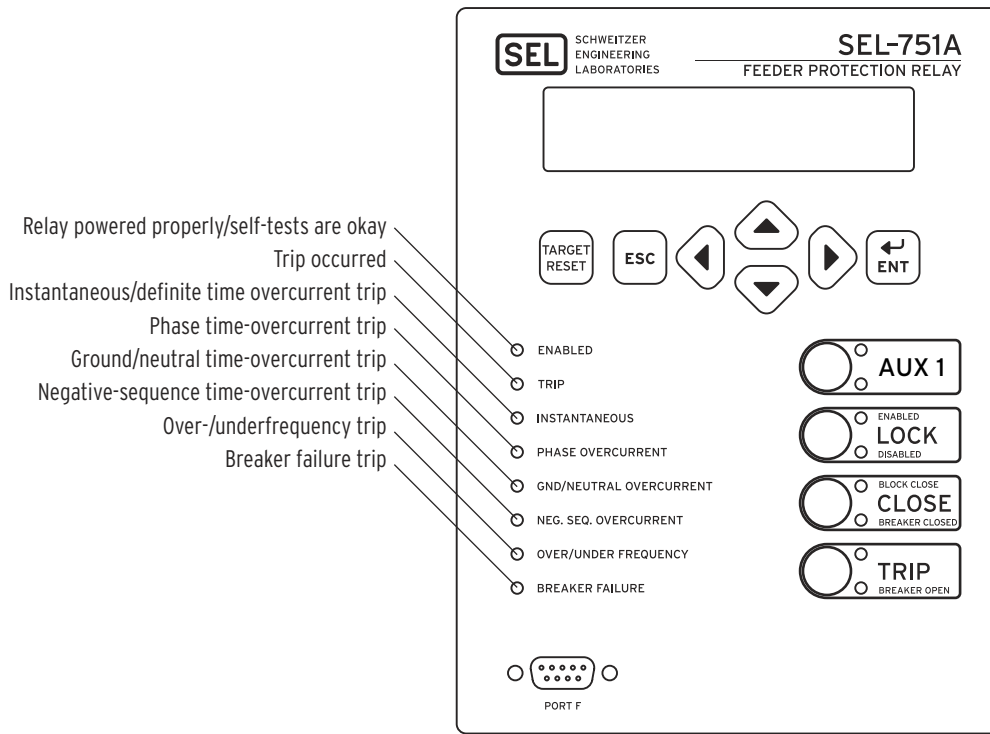
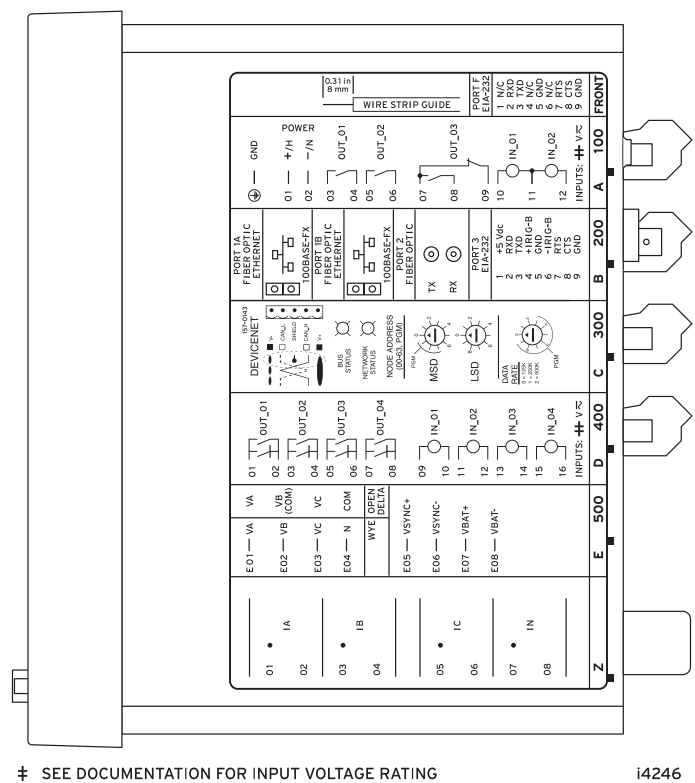
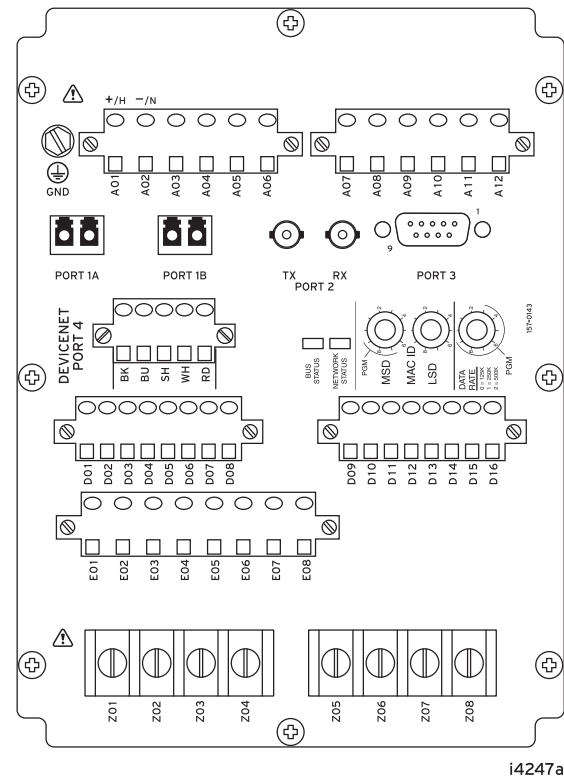

Figure 14 Front Panel With Default Configurable Labels



(A) Rear-Panel Layout

(B) Side-Panel Input and Output Designations

Figure 15 Dual Fiber Ethernet With Enhanced Voltage Option With Monitoring Package, DeviceNet, Fiber-Optic Serial Port, and Fast Hybrid 4 DI/4 DO

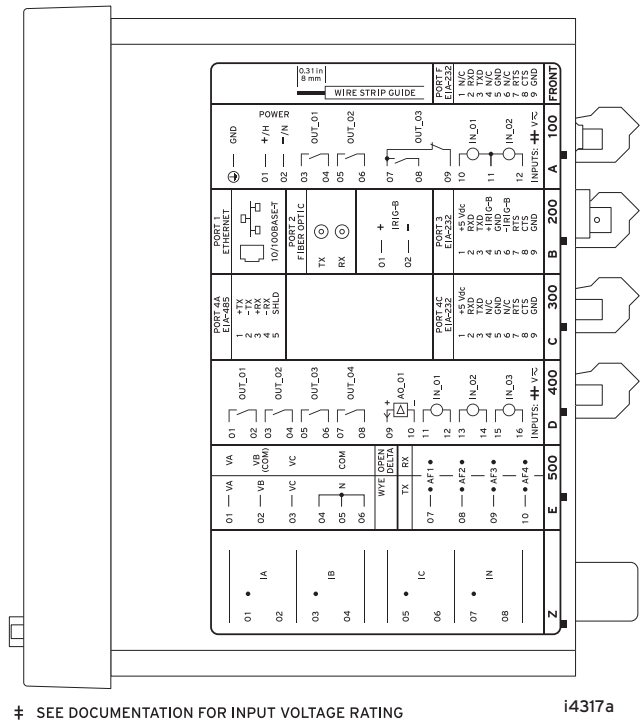
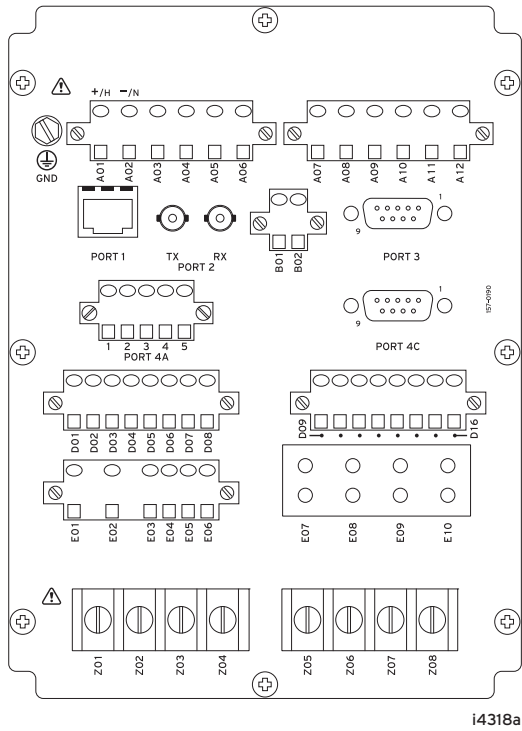

(A) Rear-Panel Layout

(B) Side-Panel Input and Output Designations

**Figure 16 Fiber-Optic Serial, Ethernet, EIA-232 Communication, 4 DO/3 DI/1 AO, and 3 AVI/4 AFDI Voltage Option With Arc-Flash Detector Inputs**

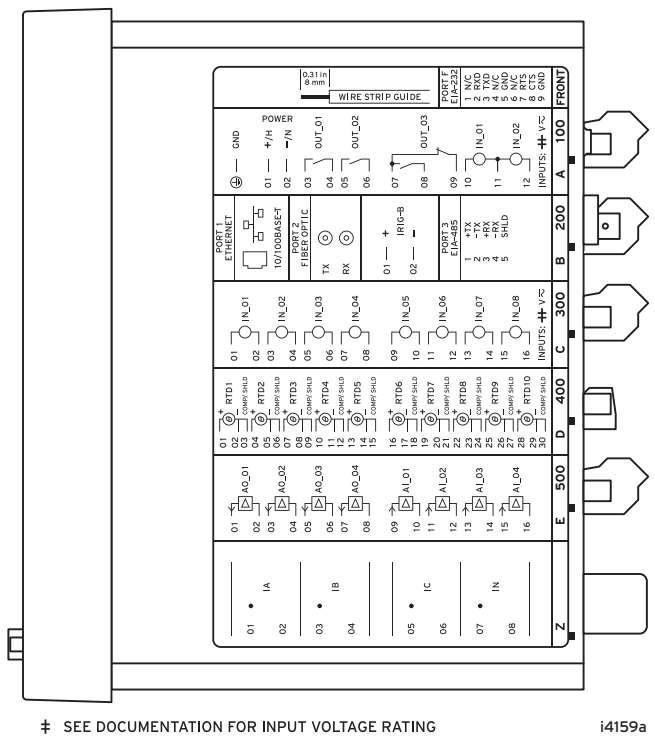
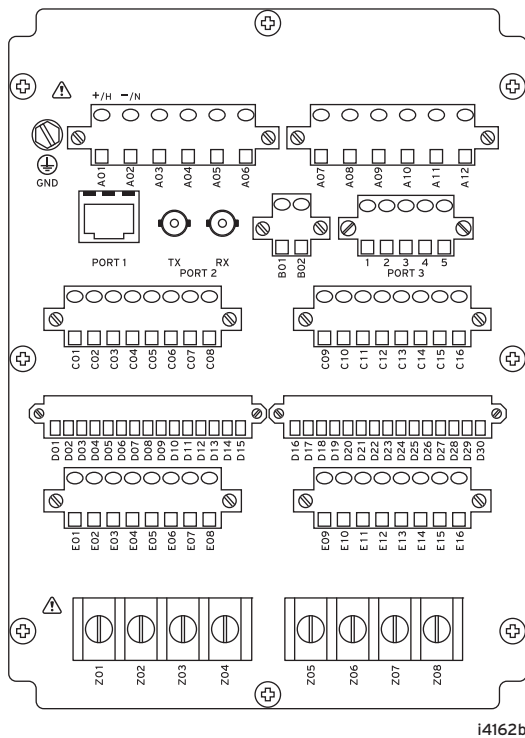

(A) Rear-Panel Layout

(B) Side-Panel Input and Output Designations

**Figure 17 Fiber-Optic Serial, Ethernet, 8 DI, RTD, and 4 AI/4 AO Option**

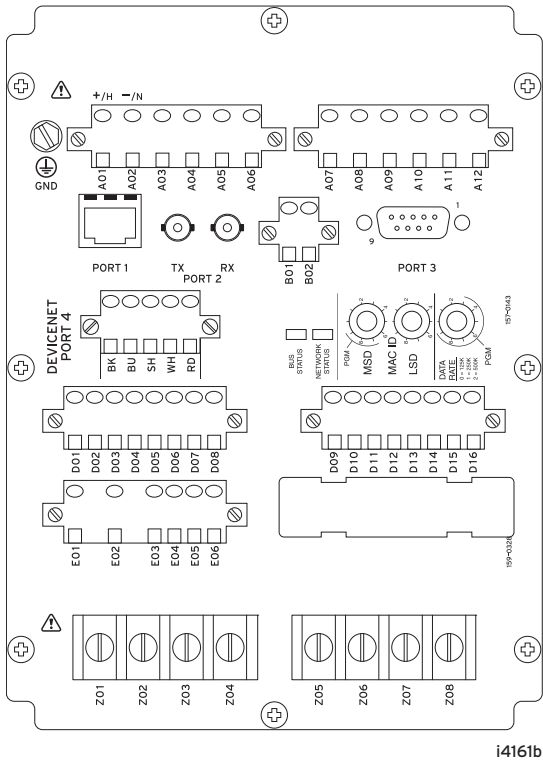

(A) Rear-Panel Layout

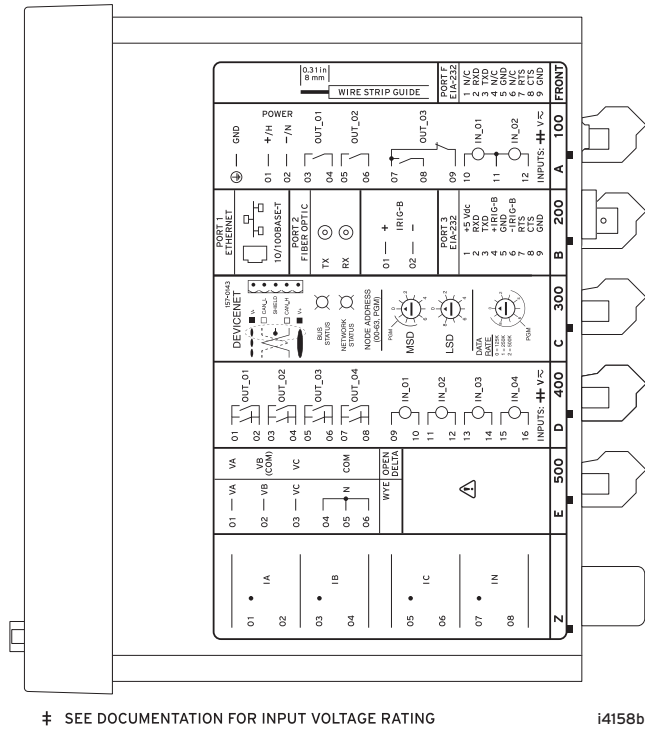

(B) Side-Panel Input and Output Designations

**Figure 18 Fiber-Optic Serial, DeviceNet, Fast Hybrid 4 DI/4 DO, and Voltage Option**

## Relay Dimensions

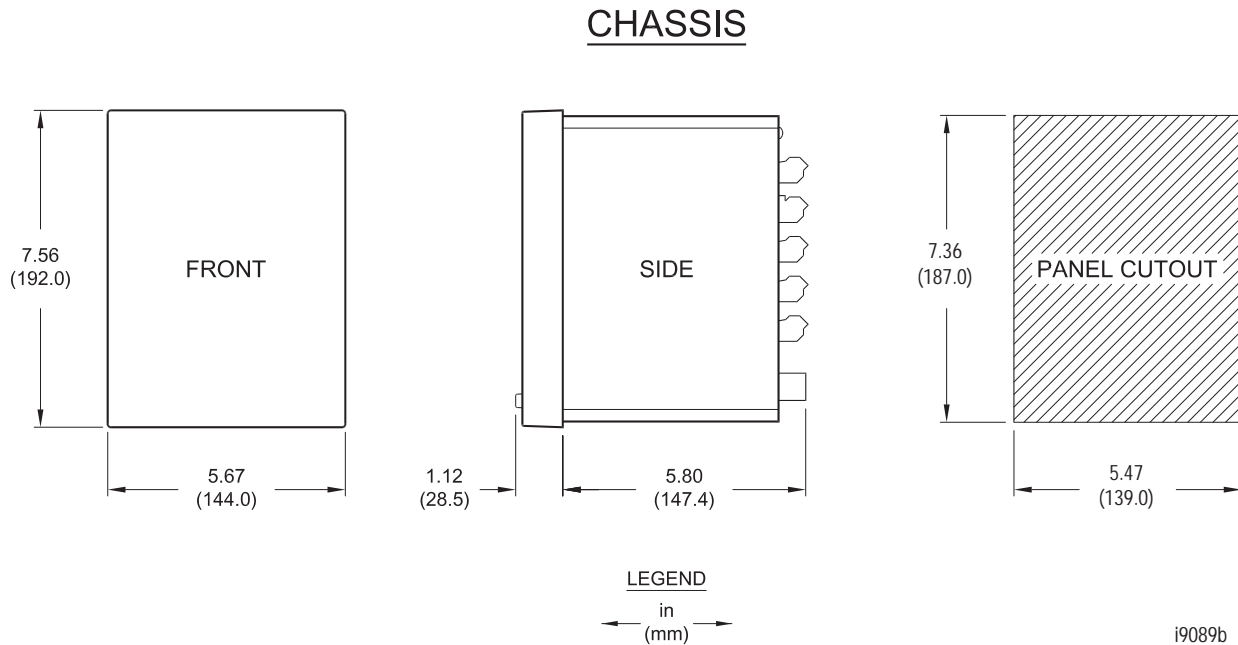

**Figure 19 SEL-751A Dimensions for Rack- and Panel-Mount Models**



# Specifications

## General

### AC Current Input

Phase, Neutral, and Residual Currents

$I_{NOM}$  = 1 A, 5 A, 50 mA, or 2.5 mA (high sensitivity) secondary depending on model.

#### INOM = 5 A

Rated Range (X/R = 40): 0.10–100.00 A

Continuous Rating: 15 A

1 Second Thermal: 500 A

Burden (Per Phase): < 0.1 VA

#### INOM = 1 A

Rated Range (X/R = 40): 0.02–20.00 A

Continuous Rating: 15 A

1 Second Thermal: 100 A

Burden (Per Phase): < 0.01 VA

#### INOM = 50 mA

Rated Range (X/R = 40): 5.0–1000.0 mA

Continuous Rating: 15 A

1 Second Thermal: 100 A

Burden (Per Phase): < 2 mVA

#### INOM = 2.5 mA

Rated Range (X/R = 40): 0.13–12.50 mA

Continuous Rating: 15 A

1 Second Thermal: 100 A

Burden (Per Phase): < 0.1 mVA

Measurement Category: II

### AC Voltage Inputs

Rated Operating Voltage ( $U_e$ ): 100–250 Vac

Rated Continuous Voltage: 300 Vac

10 Second Thermal: 600 Vac

Burden: < 0.1 VA

Input Impedance: 10 Mohm differential  
5 Mohm common mode

### Power Supply

125/250 Vdc or 120/240 Vac

Rated Supply Voltage: 110–240 Vac, 50/60 Hz  
110–250 Vdc

Input Voltage Range: 85–264 Vac  
85–275 Vdc

Power Consumption: < 40 VA (ac)  
< 20 W (dc)

Interruptions: 50 ms @ 125 Vac/Vdc  
100 ms @ 250 Vac/Vdc

24/48 Vdc

Rated Supply Voltage: 24–48 Vdc

Input Voltage Range: 19.2–60 Vdc

Power Consumption: < 20 W (dc)

Interruptions: 10 ms @ 24 Vdc  
50 ms @ 48 Vdc

## Output Contacts

### General

**OUT103** is Form C Trip output, all other outputs are Form A, except for the SELECT 4 DI/3 DO card, which supports one Form-B and two Form-C outputs.

Mechanical Durability: 10,000 no load operations

Pickup/Dropout Time: ≤ 8 ms (coil energization to contact closure)

### DC Output Ratings

Rated Operational Voltage: 250 Vdc

Rated Voltage Range: 19.2–275 Vdc

Rated Insulation Voltage: 300 Vdc

Make: 30 A @ 250 Vdc per IEEE C37.90

Continuous Carry: 6 A @ 70°C  
4 A @ 85°C

Thermal: 50 A for 1 s

Contact Protection: 360 Vdc, 40 J MOV protection across open contacts

Breaking Capacity (10,000 Operations) per IEC 60255-0-20:1974:

24 Vdc .75 A L/R = 40 ms

48 Vdc 0.50 A L/R = 40 ms

125 Vdc 0.30 A L/R = 40 ms

250 Vdc 0.20 A L/R = 40 ms

Cyclic (2.5 Cycles/Second) per IEC 60255-0-20:1974:

24 Vdc 0.75 A L/R = 40 ms

48 Vdc 0.50 A L/R = 40 ms

125 Vdc 0.30 A L/R = 40 ms

250 Vdc 0.20 A L/R = 40 ms

### AC Output Ratings

Maximum Operational Voltage ( $U_e$ ) Rating: 240 Vac

Insulation Voltage ( $U_i$ ) Rating (Excluding EN 61010-1): 300 Vac

Utilization Category: AC-15 (control of electromagnetic loads > 72 VA)

Contact Rating Designation: B300 (B = 5 A, 300 = rated insulation voltage)

Voltage Protection Across Open Contacts: 270 Vac, 40 J

Rated Operational Current ( $I_o$ ): 3 A @ 120 Vac  
1.5 A @ 240 Vac

Conventional Enclosed Thermal Current ( $I_{the}$ ) Rating: 5 A

Rated Frequency: 50/60 ± 5 Hz

Electrical Durability Make VA Rating: 3600 VA,  $\cos \phi = 0.3$

Electrical Durability Break VA Rating: 360 VA,  $\cos \phi = 0.3$

UL/CSA Digital Output Contact Temperature Derating for Operating at Elevated Temperatures

Digital Output Cards Installed	Operating Ambient	Maximum Value of Current ( $I_{the}$ )	Duty Factor
1-3	less than or equal to 60°C	5.0 A	Continuous
1-3	between 60°C and 70°C	2.5 A	Continuous

Fast Hybrid (High-Speed, High-Current Interrupting)

Make:	30 A
Carry:	6 A continuous carry at 70°C 4 A continuous carry at 85°C
1 s Rating:	50 A
Open State Leakage Current:	< 100 $\mu$ A
MOV Protection (Maximum Voltage):	250 Vac/330 Vdc
Pickup Time:	< 50 $\mu$ s, resistive load
Dropout Time:	< 8 ms, resistive load

Break Capacity (10000 Operations):

48 Vdc	10.0 A	L/R = 40 ms
125 Vdc	10.0 A	L/R = 40 ms
250 Vdc	10.0 A	L/R = 20 ms

Cyclic Capacity (4 cycles in 1 second, followed by 2 minutes idle for thermal dissipation):

48 Vdc	10.0 A	L/R = 40 ms
125 Vdc	10.0 A	L/R = 40 ms
250 Vdc	10.0 A	L/R = 20 ms

**NOTE:** Per IEC 60255-23:1994, using the simplified method of assessment.

**NOTE:** Make rating per IEEE C37.90-1989.

### Optoisolated Control Inputs

When Used With DC Control Signals

250 V:	ON for 200–312.5 Vdc OFF below 150 Vdc
220 V:	ON for 176–275 Vdc OFF below 132 Vdc
125 V:	ON for 100–156.2 Vdc OFF below 75 Vdc
110 V:	ON for 88–137.5 Vdc OFF below 66 Vdc
48 V:	ON for 38.4–60 Vdc OFF below 28.8 Vdc
24 V:	ON for 15–30 Vdc OFF for <5 Vdc

When Used With AC Control Signals

250 V:	ON for 170.6–312.5 Vac OFF below 106 Vac
220 V:	ON for 150.2–275 Vac OFF below 93.3 Vac
125 V:	ON for 85–156.2 Vac OFF below 53 Vac
110 V:	ON for 75.1–137.5 Vac OFF below 46.6 Vac
48 V:	ON for 32.8–60 Vac OFF below 20.3 Vac
24 V:	ON for 14–30 Vac OFF below 5 Vac

Current Draw at Nominal DC Voltage:	2 mA (at 220–250 V) 4 mA (at 48–125 V) 10 mA (at 24 V)
-------------------------------------	--

Rated Impulse Withstand Voltage ( $U_{imp}$ ):	4000 V
--	--------

### Analog Output (Optional)

	1A0	4A0
Current:	4–20 mA	$\pm$ 20 mA
Voltage:	—	$\pm$ 10 V
Load at 1 mA:	—	0–15 k $\Omega$
Load at 20 mA:	0–300 $\Omega$	0–750 $\Omega$
Load at 10 V:	—	>2000 $\Omega$
Refresh Rate:	100 ms	100 ms
% Error, Full Scale, at 25°C:	< $\pm$ 1%	< $\pm$ 0.55%
Select From:	Analog quantities available in the relay	

### Analog Inputs (Optional)

Maximum Input Range:	$\pm$ 20 mA $\pm$ 10 V Operational range set by user
Input Impedance:	200 $\Omega$ (current mode) >10 k $\Omega$ (voltage mode)
Accuracy at 25°C:	
With User Calibration:	0.05% of full scale (current mode) 0.025% of full scale (voltage mode)
Without User Calibration:	Better than 0.5% of full scale at 25°C
Accuracy Variation With Temperature:	$\pm$ 0.015% per °C of full-scale ( $\pm$ 20 mA or $\pm$ 10 V)

### Arc-Flash Detectors (Optional)

Multimode fiber-optic receiver/transmitter pair	
Fiber Type:	1000 $\mu$ m diameter, 640 nm wavelength, plastic, bare, or jacketed
Connector Type:	V-Pin

### Frequency and Phase Rotation

System Frequency:	50, 60 Hz
Phase Rotation:	ABC, ACB
Frequency Tracking:	15–70 Hz

### Time-Code Input

Format:	Demodulated IRIG-B
On (1) State:	$V_{ih} \geq 2.2$ V
Off (0) State:	$V_{il} \leq 0.8$ V
Input Impedance:	2 k $\Omega$
Accuracy:	Relay time is synchronized to within $\pm$ 1 ms of time-source input.
Simple Network Time Protocol (SNTP) Accuracy Internal Clock:	$\pm$ 5 ms

### Communications Ports

Standard EIA-232 (2 Ports)

Location:	Front Panel Rear Panel
Data Speed:	300–38400 bps

**EIA-485 Port (Optional)**

Location:	Rear Panel
Data Speed:	300–19200 bps

**Ethernet Port (Optional)**

Single/Dual 10/100BASE-T copper (RJ-45 connector)  
Single/Dual 100BASE-FX (LC connector)

**Multimode Fiber-Optic Port (Optional)**

Location:	Rear panel
Data Speed:	300–38400 bps

**Fiber-Optic Ports Characteristics****Port 1 (or 1A, 1B) Ethernet**

Wavelength:	1300 nm
Optical Connector Type:	LC
Fiber Type:	Multimode
Link Budget:	16.1 dB
Typical TX Power:	–15.7 dBm
RX Min. Sensitivity:	–31.8 dBm
Fiber Size:	62.5/125 $\mu$ m
Approximate Range:	~6.4 Km
Data Rate:	100 Mb
Typical Fiber Attenuation:	–2 dB/Km

**Port 2 Serial**

Wavelength:	820 nm
Optical Connector Type:	ST
Fiber Type:	Multimode
Link Budget:	8 dB
Typical TX Power:	–16 dBm
RX Min. Sensitivity:	–24 dBm
Fiber Size:	62.5/125 $\mu$ m
Approximate Range:	~1 Km
Data Rate:	5 Mb
Typical Fiber Attenuation:	–4 dB/Km

**Channels 1-4 Arc-Flash Detectors (AFDI)**

Wavelength:	640 nm
Optical Connector Type:	V-Pin
Fiber Type:	Multimode
Link Budget:	27 dB
Typical TX Power:	–12 dBm
RX Min. Sensitivity:	–39 dBm
Fiber Size:	1000 $\mu$ m
Approximate Range:	To 35 m (Point Sensor) To 70 m (Bare-Fiber Sensor)
Data Rate:	NA
Typical Fiber Attenuation:	–0.15 dB/m

**Optional Communications Cards**

Option 1:	EIA-232 or EIA-485 communications card
Option 2:	DeviceNet communications card

**Communications Protocols**

SEL, Modbus, DNP3, FTP, TCP/IP, Telnet, SNMP, IEC 61850, MIRRORING BITS, EVMSG, C37.118 (synchrophasors) and DeviceNet.

**Operating Temperature**

IEC Performance Rating  
(Per IEC/EN 60068-2-1 & 60068-2-2): –40° to +85°C (–40° to +185°F)

**NOTE:** Not applicable to UL applications.

**NOTE:** LCD contrast impaired for temperatures below –20°C and above +70°C.

DeviceNet Communications

Card Rating: +60°C (140°F) maximum

**Operating Environment**

Pollution Degree:	2
Overvoltage Category:	II
Atmospheric Pressure:	80–110 kPa
Relative Humidity:	5–95%, noncondensing
Maximum Altitude:	2000 m

**Dimensions**

144.0 mm (5.67 in.) x 192.0 mm (7.56 in.) x 147.4 mm (5.80 in.)

**Weight**

2.7 kg (6.0 lbs)

**Relay Mounting Screws (#8-32) Tightening Torque**

Minimum:	1.4 Nm (12 in-lb)
Maximum:	1.7 Nm (15 in-lb)

**Terminal Connections**

Terminal Block

Screw Size:	#6
Ring Terminal Width:	0.310" maximum

Terminal Block Tightening Torque

Minimum:	0.9 Nm (8 in-lb)
Maximum:	1.4 Nm (12 in-lb)

Compression Plug Tightening Torque

Minimum:	0.5 Nm (4.4 in-lb)
Maximum:	1.0 Nm (8.8 in-lb)

Compression Plug Mounting Ear Screw Tightening Torque

Minimum:	0.18 Nm (1.6 in-lb)
Maximum:	0.25 Nm (2.2 in-lb)

**Type Tests****Environmental Tests**

Enclosure Protection:	IEC 60529:2001 + CRDG:2003 IP65 enclosed in panel IP20 for terminals IP54 rated terminal dust protection assembly (SEL Part #915900170). 10°C temperature derating applies to the temperature specifications of the relay.
Vibration Resistance:	IEC 60068-2-6:2007 3 G, 10–150 Hz IEC 60255-21-1:1988, Class 1 IEC 60255-21-3:1993, Class 2
Shock Resistance:	IEC 60255-21-2:1988, Class 1

Cold:	IEC 60068-2-1:2007 -40°C, 16 hours
Damp Heat, Steady State:	IEC 60068-2-78:2001 40°C, 93% relative humidity, 4 days
Damp Heat, Cyclic:	IEC 60068-2-30:2005 25–55°C, 6 cycles, 95% relative humidity
Dry Heat:	IEC 60068-2-2:2007 85°C, 16 hours

### Dielectric Strength and Impulse Tests

Dielectric (HiPot):	IEC 60255-5:2000 IEEE C37.90-2005 2.5 kVac on current inputs, ac voltage inputs, contact I/O 2.0 kVac on analog inputs 1.0 kVac on analog outputs 2.83 kVdc on power supply
Impulse:	IEC 60255-5:2000 IEEE C37.90-2005 0.5 J, 4.7 kV on power supply, contact I/O, ac current and voltage inputs 0.5 J, 530 V on analog outputs

### RFI and Interference Tests

EMC Immunity	
Electrostatic Discharge Immunity:	IEC 61000-4-2:2008 IEC 60255-22-2:2008 Severity Level 4 8 kV contact discharge 15 kV air discharge
Radiated RF Immunity:	IEC 61000-4-3:2010 IEC 60255-22-3:2007 10 V/m IEEE C37.90.2-2004 35 V/m
Digital Radio Telephone RF Immunity:	ENV 50204:1995
Fast Transient, Burst Immunity:	IEC 61000-4-4:2004 IEC 60255-22-4:2008 4 kV @ 5.0 kHz 2 kV @ 5.0 kHz for comm. ports
Surge Immunity:	IEC 61000-4-5:2005 IEC 60255-22-5:2008 2 kV line-to-line 4 kV line-to-earth
Surge Withstand Capability Immunity:	IEC 60255-22-1:2007 2.5 kV common mode 1 kV differential mode 1 kV common mode on comm. ports IEEE C37.90.1-2002 2.5 kV oscillatory 4 kV fast transient
Conducted RF Immunity:	IEC 61000-4-6:2008 IEC 60255-22-6:2001 10 Vrms
Magnetic Field Immunity:	IEC 61000-4-8:2009 1000 A/m for 3 seconds 100 A/m for 1 minute IEC 61000-4-9:2001 1000 A/m
Power Supply Immunity:	IEC 60255-11:2008

EMC Emissions	
Conducted Emissions:	EN 55011:1998, Class A IEC 60255-25:2000
Radiated Emissions:	EN 55011:1998, Class A IEC 60255-25:2000

### Electromagnetic Compatibility

Product Specific:	EN 50263:1999
-------------------	---------------

### Certifications

ISO 9001:	This product was designed and manufactured under an ISO 9001 certified quality management system.
UL, cUL*:	Protective Relay Category NRGU, NRGU7 per UL 508, C22.2 No. 14

\* UL has not yet developed requirements for products intended to detect and mitigate an arc flash; consequently, UL has not evaluated the performance of this feature. While UL is developing these requirements, it will place no restriction on the use of this product for arc-flash detection and mitigation. For test results performed by an independent laboratory and other information on the performance and verification of this feature, please contact SEL customer service.

CSA:	C22.2 No. 61010-1
CE:	CE Mark–EMC Directive Low Voltage Directive IEC 61010-1:2001 IEC 60947-1 IEC 60947-4-1 IEC 60947-5-1
Hazardous Locations Approvals:	Complies with UL1604, ISA 12.12.01, CSA 22.2 No. 213, and EN 60079-15 (Class 1, Division 2).

### Processing Specifications and Oscillography

AC Voltage and Current Inputs:	16 samples per power system cycle
Frequency Tracking Range:	15–70 Hz
Digital Filtering:	One-cycle cosine after low-pass analog filtering. Net filtering (analog plus digital) rejects dc and all harmonics greater than the fundamental.
Protection and Control Processing:	Processing interval is 4 times per power system cycle (except for math variables and analog quantities, which are processed every 100 ms)
Arc Flash Processing:	Arc Flash light is sampled 32 times per cycle. Arc Flash current, light, and 2 fast hybrid outputs are processed 16 times per cycle.

### Oscillography

Length:	15 or 64 cycles
Sampling Rate:	16 samples per cycle, unfiltered 4 samples per cycle, filtered
Trigger:	Programmable, using Boolean expressions
Format:	ASCII and Compressed ASCII
Time-Stamp Resolution:	1 ms
Time-Stamp Accuracy:	±5 ms

**Sequential Events Recorder**

Time-Stamp Resolution:	1 ms
Time-Stamp Accuracy (With Respect to Time Source):	±5 ms

**Relay Elements****Instantaneous/Definite-Time Overcurrent (50P, 50G, 50N, 50Q)**

Pickup Setting Range, A Secondary	
5 A Models:	0.50–100.00 A, 0.01 A steps
1 A Models:	0.10–20.00 A, 0.01 A steps
50 mA Models:	5.0–1000.0 mA, 0.1 mA steps
2.5 mA Models:	0.13–12.50 mA, 0.01 mA steps
	(The 50N elements in the 2.5 mA and 50 mA models have a built-in 30 ms security qualifier time delay.)
Accuracy:	±5% of setting ±0.02 • I <sub>NOM</sub> A secondary (Steady State pickup)
Time Delay:	0.00–5.00 seconds, 0.01 seconds steps
Pickup/Dropout Time:	<1.5 cycles

**Arc-Flash Instantaneous Overcurrent (50PAF, 50NAF)**

Pickup Setting Range, A Secondary	
5 A Models:	0.50–100.00 A, 0.01 A steps
1 A Models:	0.10–20.00 A, 0.01 A steps
Accuracy:	0 to +10% of setting ±0.02 • I <sub>NOM</sub> A secondary (Steady State pickup)
Pickup/Dropout Time:	2–5 ms/1 cycle

**Arc-Flash Time-Overlight (TOL1-TOL4)**

Pickup Setting Range, % of Full Scale:	3.0–20.0%
Pickup/Dropout Time:	2–5 ms/1 cycle

**Inverse-Time Overcurrent (51P, 51G, 51N, 51Q)**

Pickup Setting Range, A Secondary:	
5 A Models:	0.50–16.00 A, 0.01 A steps
1 A Models:	0.10–3.20 A, 0.01 A steps
50 mA Models:	5.0–160.0 mA, 0.1 mA steps
2.5 mA Models:	0.13–2.00 mA, 0.01 mA steps
Accuracy:	±5% of setting ±0.02 • I <sub>NOM</sub> A secondary (Steady State pickup)
Time Dial	
U.S.:	0.50–15.00, 0.01 steps
IEC:	0.05–1.00, 0.01 steps
Accuracy:	±1.5 cycles, ±4% between 2 and 30 multiples of pickup (within rated range of current)

**Undervoltage (27)**

Setting Range:	Off, 0.02–1.00 • V <sub>nm</sub>
Accuracy:	±1% of setting ±0.5 V (±5% of setting ±2 V with the xx71xx card)
Pickup/Dropout Time:	<1.5 cycles

**Overvoltage (59, 59G, 59Q)**

Setting Range:	Off, 0.02–1.20 • V <sub>nm</sub>
Accuracy:	±1% of setting ±0.5 V (±5% of setting ±2 V with the xx71xx card)
Pickup/Dropout Time:	<1.5 cycles

**Power Elements (32)**

Instantaneous/Definite Time, 3 Phase Elements Type:	
	+W, –W, +VAR, –VAR
Pickup Setting Range, VA Secondary:	
5 A Models:	1.0–6500.0 VA, 0.1 VA steps
1 A Models:	0.2–1300.0 VA, 0.1 VA steps
Accuracy:	±0.10 A • (L-L voltage secondary) and ±5% of setting at unity power factor for power elements and zero power factor for reactive power elements (5 A nominal) ±0.02 A • (L-L voltage secondary) and ±5% of setting at unity power factor for power elements and zero power factor for reactive power elements (1 A nominal)
Pickup/Dropout Time:	<10 cycles

**Power Factor (55)**

Setting Range:	Off, 0.05–0.99
Accuracy:	±5% of full scale for current ≥ 0.5 • I <sub>NOM</sub>

**Frequency (81)**

Setting Range:	Off, 20.00–70.00 Hz
Accuracy:	±0.01 Hz (V <sub>1</sub> > 60 V) with voltage tracking ±0.05 Hz (I <sub>1</sub> > 0.8 • I <sub>nom</sub> ) with current tracking
Pickup/Dropout Time:	<4 cycles

**Rate-of-Change of Frequency (81R)**

Setting Range:	Off, 0.10–15.00 Hz/s
Accuracy:	±100 mHz/s, ±3.33% of pickup

**Synchronism Check (25)**

Pickup Range, Secondary Voltage:	0.00–300.00 V
Pickup Accuracy, Secondary Voltage:	±1% ±0.5 volts (over the range of 12.5–300 V)
Slip Frequency Pickup Range:	0.05 Hz–0.50 Hz
Slip Frequency Pickup Accuracy:	±0.05 Hz
Phase Angle Range:	0–80°
Phase Angle Accuracy:	±4°

**Synchronism-Check Undervoltage (27S)**

Setting Range:	Off, 2.00–300.00 V
Accuracy:	±1% of setting ±0.5 V (over the range of 12.5–300 V)
Pickup/Dropout Time:	<1.5 cycles



**Synchronism-Check Overvoltage (59S)**

Setting Range:	Off, 2.00–300.00 V
Accuracy:	±1% of setting ±0.5 V (over the range of 12.5–300 V)
Pickup/Dropout Time:	<1.5 cycles

**Station Battery Voltage Monitor**

Operating Range:	0–350 Vdc (300 Vdc for UL purposes)
Pickup Range:	20.00–300.00 Vdc
Pickup Accuracy:	±2% of setting ±2 Vdc

**Timers**

Setting Range:	Various
Accuracy:	±0.5% of setting ±1/4 cycle

**RTD Protection**

Setting Range:	Off, 1–250°C
Accuracy:	±2°C
RTD Open-Circuit Detection:	>250°C
RTD Short-Circuit Detection:	<–50°C
RTD Types:	PT100, NI100, NI120, CU10
RTD Lead Resistance:	25 ohm max. per lead

Update Rate:	<3 s
Noise Immunity on RTD Inputs:	To 1.4 Vac (peak) at 50 Hz or greater frequency

**Metering**

Accuracies are specified at 20°C, nominal frequency, ac currents within (0.4–20.0) • I<sub>NOM</sub> A secondary, and ac voltages within 50–250 V secondary unless otherwise noted.

Phase Currents:	±2% of reading, ±2°
3-Phase Average Current:	±2% of reading
Current Imbalance (%):	±2% of reading
IG (Residual Current):	±3% of reading, ±2°
IN (Neutral Current):	±2% of reading, ±2°
3I2 Negative-Sequence Current:	±3% of reading
System Frequency:	±0.01 Hz of reading for frequencies within 20.00–70.00 Hz (V1 > 60 V) with voltage tracking ±0.05 Hz of reading for frequencies within 20.00–70.00 Hz (I1 > 0.8 • Inom) with current tracking
Line-to-Line Voltages:	±1% of reading (±2% with the xx71xx card), ±1° for voltages within 24–264 V

Provided by Northeast Power Systems, Inc.  
[www.nepsi.com](http://www.nepsi.com)

© 2007–2013 by Schweitzer Engineering Laboratories, Inc. All rights reserved.

All brand or product names appearing in this document are the trademark or registered trademark of their respective holders. No SEL trademarks may be used without written permission. SEL products appearing in this document may be covered by U.S. and Foreign patents.

Schweitzer Engineering Laboratories, Inc. reserves all rights and benefits afforded under federal and international copyright and patent laws in its products, including without limitation software, firmware, and documentation.

The information in this document is provided for informational use only and is subject to change without notice. Schweitzer Engineering Laboratories, Inc. has approved only the English language document.

This product is covered by the standard SEL 10-year warranty. For warranty details, visit [www.selinc.com](http://www.selinc.com) or contact your customer service representative.

**SCHWEITZER ENGINEERING LABORATORIES**

2350 NE Hopkins Court • Pullman, WA 99163-5603 USA  
 Phone: +1.509.332.1890 • Fax: +1.509.332.7990  
 Internet: [www.selinc.com](http://www.selinc.com) • E-mail: [info@selinc.com](mailto:info@selinc.com)

