

Joslyn Clark



SERVICE BULLETIN MVC 7707

USAVAC VACUUM CONTACTOR
Instruction Manual 200, 400, 600, 1100A,
2.5 - 5.0 - 7.2KV

Inspection
General Description
Operation
Installation
Maintenance

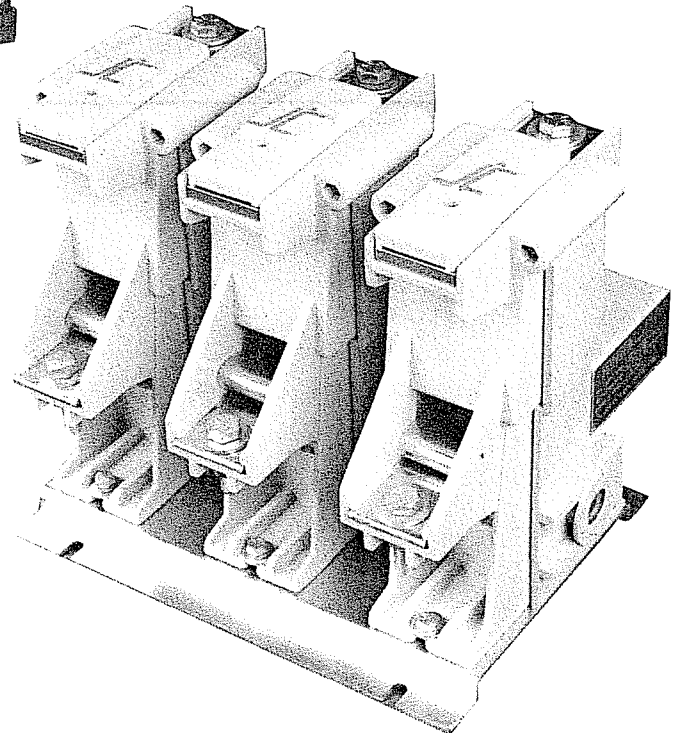
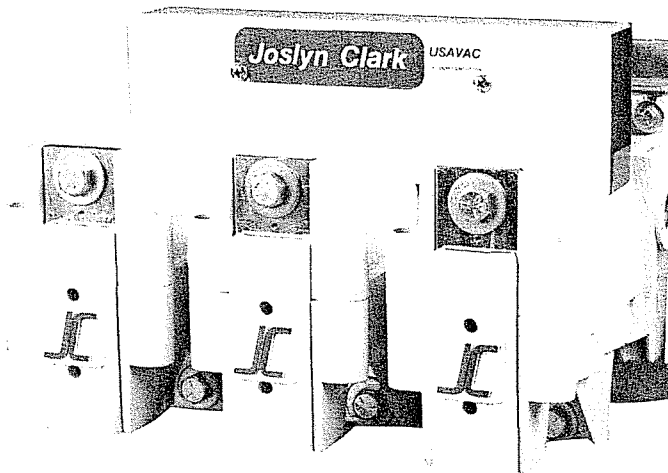

Provided by Northeast Power Systems, Inc.
www.nepsi.com

Joslyn Clark Controls, Inc.

PO Box 945, Rt. 4 Rock Hill Hwy, Lancaster, SC 29720, Phone 803-286-8491 Fax : 803-285-0885

NOTE: READ ALL INSTRUCTIONS BEFORE WORKING ON THIS EQUIPMENT. PRECAUTIONS

DANGER

HAZARD OF ELECTRICAL SHOCK OR BURN

POWER MUST BE DISCONNECTED FROM THE CONTROLLER AND CONTACTOR PRIOR TO PERFORMING ANY INSTALLATION OR MAINTENANCE. THE EQUIPMENT HAS BEEN DESIGNED TO PERMIT MAINTENANCE AND/OR TESTING ON THOSE COMPONENTS THAT ARE DISCONNECTED FROM THE MAIN POWER. WHEN PERFORMING THIS WORK, EXTREME CAUTION MUST BE EXERCISED IN VIEW OF THE PRESENCE OF HAZARDOUS VOLTAGE.

The following list of "PRECAUTIONS" must be studied and followed during installation, operation and servicing of the equipment.

1. Read this service bulletin prior to installing or operating the equipment.
2. If motor controllers and/or contactors are to be stored prior to installation, they must be protected from the weather and be kept free of condensation and dust.
3. Use extreme care when moving or positioning contactors (even if boxed) as they contain devices and mechanisms which may be damaged by rough handling.
4. Be sure all barriers and terminal covers are in place before operating controllers.
5. Only authorized personnel should be permitted to operate or service the contactors and controllers.

INTRODUCTION

This instruction manual covers the description, inspection, installation, operation and maintenance of Joslyn Clark's USAVAC medium voltage vacuum contactors.

GENERAL DESCRIPTION

The USAVAC vacuum contactors are available in the following three phase ratings.

Voltage (KV)	Current Rating Amp.			
	2.2 - 2.5	200	400	600
4.16	200	400	600	1100
6.6	200	400	600	1100

They are also available as high current switches in the following single phase single pole and single phase double pole ratings.

Single Phase Single Pole Amp.				
2.2 - 2.5KV	1000	1500	2000	3000
4.16KV	1000	1500	2000	3000
6.6KV	1000	1500	2000	3000

Single Phase Double Pole Amp.					
2.2 - 2.5KV	200	400	600	1100	1500
4.16KV	200	400	600	1100	1500
6.6KV	200	400	600	1100	1500

In addition contactors are available and may be supplied as open type or enclosed combination or non combination starters, full or reduced voltage types or mechanically interlocked reversing contactors or starters. The contactors are rated 240V - 7200V. Ac 50 - 60Hz. The interrupt ratings of the contactor are as follows.

E1 Interrupt Rating	200A	400A	600A
2.5Kv	25MVA	Equivalent to 5.77KA	
5.0Kv	50MVA	Equivalent to 5.77KA	
7.2Kv	60MVA	Equivalent to 4.81KA	

The contactors should be applied with coordinated short circuit protective devices (ie fuses). The coordinated rating of the contactors, when applied with fuses, is 400MVA, 45.7KA Rms withstand peak 57.8KA at 5.0KV with maximum fuse size of 38R. It is important to select the correct size and rating of fuses "E" rated for transformer protection "R" rated for motor protection. Manufacturers of these fuses do define fuse selection data and tables based on Motor Full Load current, Locked Rotor Current starting time, and # of starts/hour. Examples of manufactures are Gould - Westinghouse , General Electric, Bussman, English Electric, this is not however the complete list of manufacturers.

WARNING:

Fuse Ratings vary between different manufactures and are not necessarily interchangeable and must be checked for all Hp ratings.

SAFETY WARNING

WHEN APPLYING CONTACTORS SAFETY CODES STATE THAT A VISIBLE DISCONNECT MEANS MUST BE PROVIDED WITHIN THE CONTACTOR ENCLOSURE AND INTER-LOCKED TO PREVENT PERSONNEL ACCESS TO ELECTRICALLY LIVE PARTS. EXTREME CAUTION MUST ALWAYS BE EXERCISED IN VIEW OF THE PRESENCE OF HAZARDOUS VOLTAGES

NEVER RELY ON THE CONTACTOR GAP FOR VOLTAGE ISOLATION

INSPECTION - UNPACKING

Before the contactor is placed in service, check carefully for shipping damage. Any damage should be reported to the carrier within (3) three days of receipt. For overseas deliveries, it is important to obtain a certificate of examination from the nearest insurance inspector and photographs of the damage. This and other evidence should accompany any communication to the insurance company or shippers. In the event equipment is to be returned to the factory,

contact Joslyn Clark Customer Service Department for return authorization. A returned material authorization (RMA) number will be issued which should appear on all correspondence and the returned container.

The USAVAC Vacuum Contactor is shipped in a shock resistant foam filled cardboard box. The following steps should be taken when unpacking the contactor:

1. Check packing list against the order to make sure shipment is complete and components received are correct.
2. Examine shipping box before unpacking the contactor to make sure it has not been damaged in transit. If shipping box is damaged, pay particular attention when unpacking to see if contents are also damaged. Notify carrier if damage is found. Also, notify your local Joslyn Clark field sales office of damage.

The contactor is a modular design using high strength molded housings. The construction has very limited hardware. The principle parts are:

1. Pole or Phase Assembly
2. Control Module
3. Drive Shaft and Base

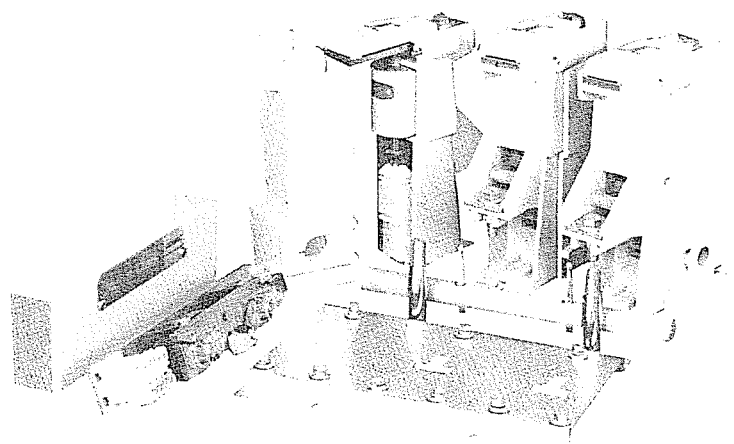

The modular design allows for two/three or multipole configurations to be easily assembled. The pole or phase assembly contains the vacuum interrupter, pull rod opening and overtravel springs. The assembly is factory set and has no requirement for adjustment or resetting. Should the vacuum interrupter need replacing, a replacement factory set half shell assembly is utilized and is simply unbolted and replaced into the fixed half shell assembly.

The control module is a removable assembly containing all control components, ie., coils, rectifier, MOV, economizing circuit auxiliary switches, terminal board, and pilot relay providing as standard 2 n/o 2 n/c isolated contacts for customer use. An option allows for 2 n/o 2 n/c extra contacts to be added to this relay. The modular concept again allows for the control circuit module to be easily removed and quick replacement of a spare module.

The removed module can then be more easily checked in a service area or workshop.

MOUNTING

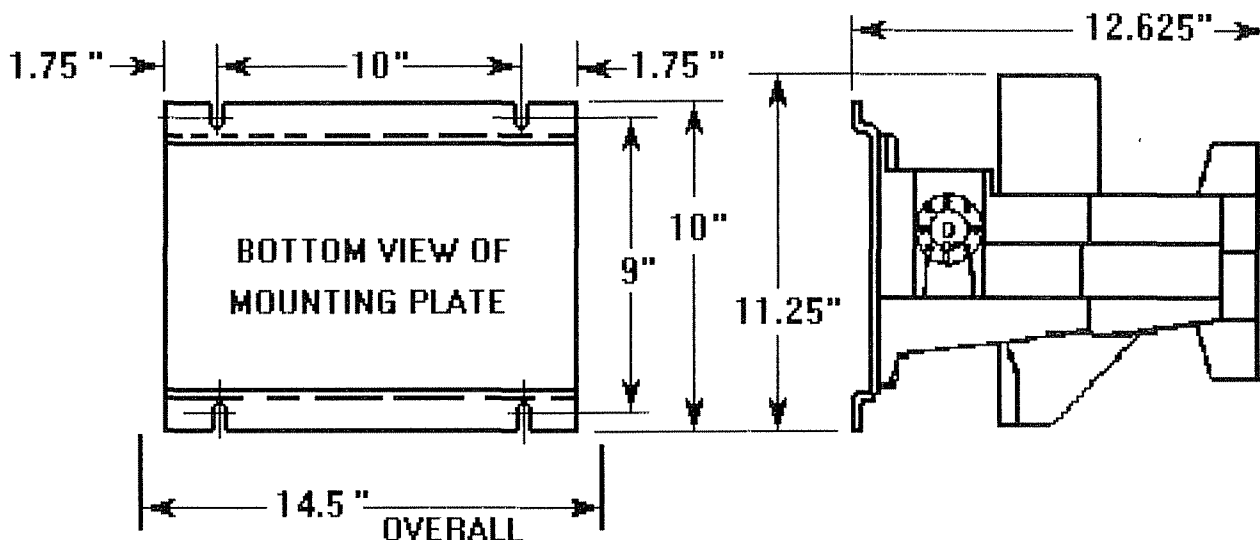

OPERATION

The vacuum interrupter contacts are held open by an opening spring held in compression, and one spring is provided per interrupter or phase assembly. Closing coils are d.c. activated, and designed to overcome the force of the opening springs. During closing the main contacts touch and additional overtravel force is provided by an additional spring held in compression mounted in the interrupter stem. The overtravel spring, one per pole or interrupter, provides additional contact force. The overtravel allows for contact erosion and therefore provides a self-adjusting feature should contact erosion occur.

Contact pressure is applied immediately behind the moving contact, which greatly reduces contact bounce, and provides considerable stored energy to cause a high separation velocity of the contacts. In the final closing movement of the armature, the economizing circuit is activated. This contact is housed in the module housing and requires no adjustment. Activation of the economizing circuit reduces the power consumption in the "hold in" mode to 7 VA per module. The heat dissipation is extremely low, to maximize component life.

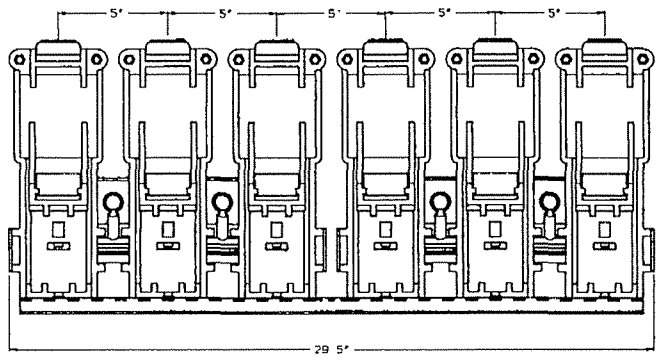

2 5/5 0/7 2KV 1100A 3 Phase
 2 5/5 0/7 2KV 1000, 1500A 2 pole
 2 5/5 0/7 2KV 2000,3000A 1 Pole

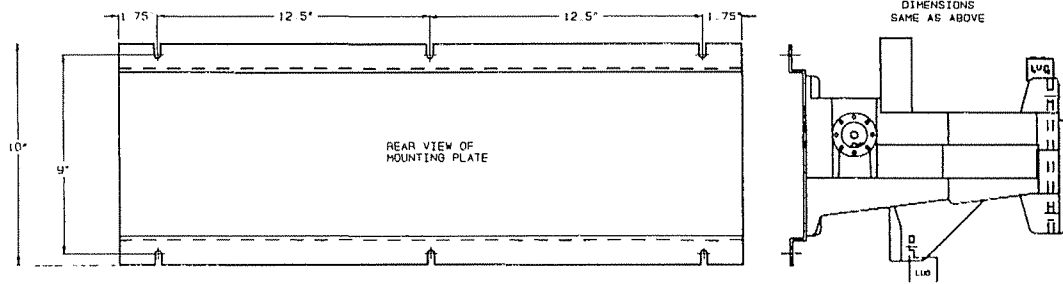

Fig. 2

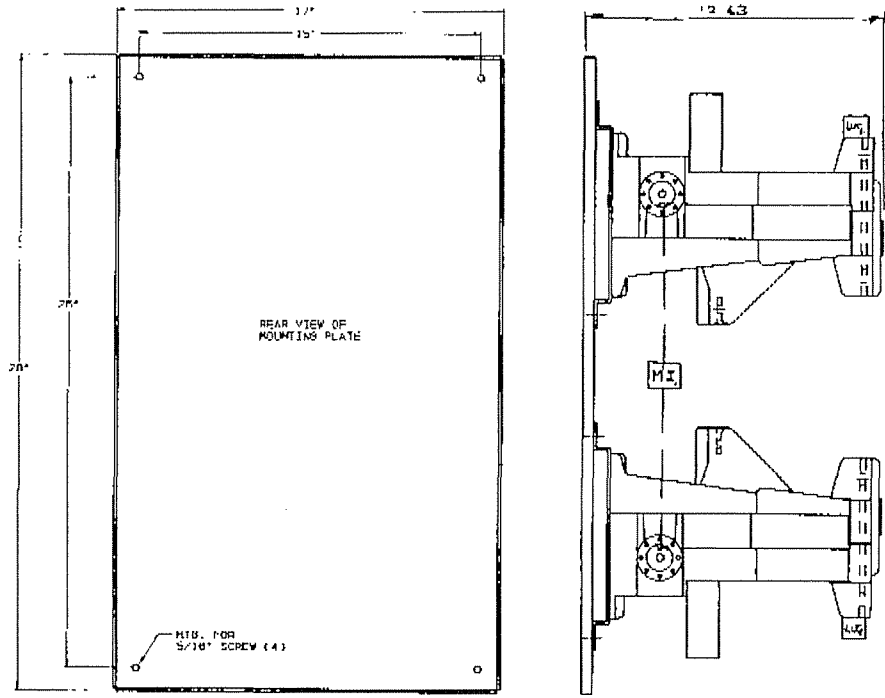

Fig. 3

2 5/5 0/7 2KV 200, 400, 600A
 Mechanically Interlocked
 or Reversing Contactors

NOTE

- 1. Recommended Mounting Hardware
5/16 " (Not Supplied)
- 2. Terminal Hardware 1/2 " (Supplied)

CONNECTIONS

Lug or crimp connectors may be used. Lug Kits are available as an option. Refer to table below. Cable supports must be used where large cables might transmit large mechanical loads to the contactors terminals. Connect lug or crimp connectors to the line and load terminals using the supplied hardware. Torque to 275 in -lbs.

CAUTION
TO PREVENT DAMAGE AND TERMINAL DEFORMATION USE DOUBLE WRENCHES WHERE PRACTICAL TO CONNECT CABLES TO LINE AND LOAD TERMINALS. SECURE LUG OR CRIMP WHILE TIGHTENING CABLE. DO NOT WRENCH CABLE OR CONNECTOR BY PULLING ON CABLE WHEN CONNECTOR IS TORQUED DOWN.

Torque cable connection bolts to 275 in lbs. If box lugs are used, torque lug connection bolts after clamping cable into lug. See table below for lug torque information when using type KVCL 350 or 500 lug kits.

Contactor Rating 200/400/600/1100A		
Lug Kit	KVCL 350	KVCL 500
Cable Size	# 4-350 MCM	# 4-500 MCM
Lug Torque	in lbs. 275	in lbs. 275

Lug Kits KVCL (Optional) 3 Lugs Per Kit.

Fig 4 and 5 Illustrates the alternative position for line side connections allowing for fixed or withdrawable designs. Fig 4 is arranged for in line cable run and Fig 5 allows for cable run in and out, on one side of contactor only.

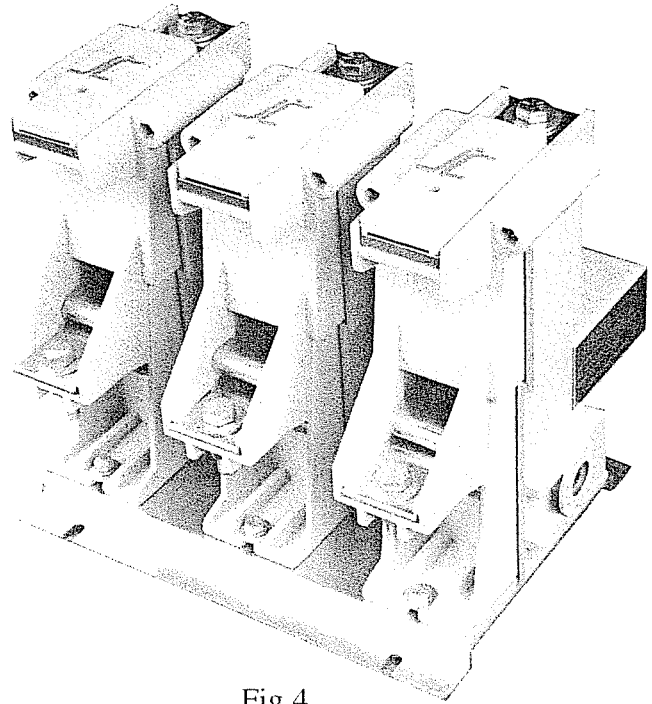

Fig 4

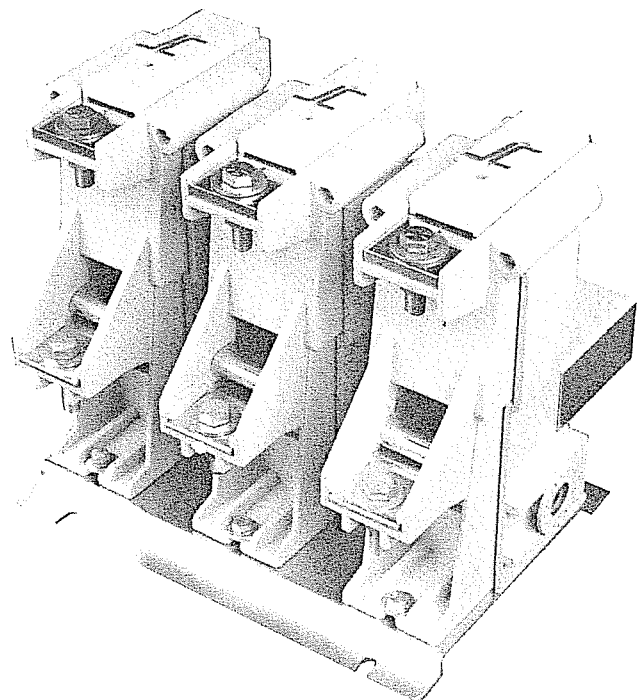

Fig5

CONTROL POWER

Contactors are available suitable for 120V or 240 Ac 50/400 Hz input control supply. Voltages are **not** field reconnectable. The ac. supply is connected to terminals 1 & 2 see Fig 6 & Fig 7 showing the diagram for 120V or 240V connections respectively which is as shown in the decal on the contactor. Note the 1100A contactor has two (2) modules and therefore twice as many aux. contacts are available, refer to the schematic below for full terminal data.

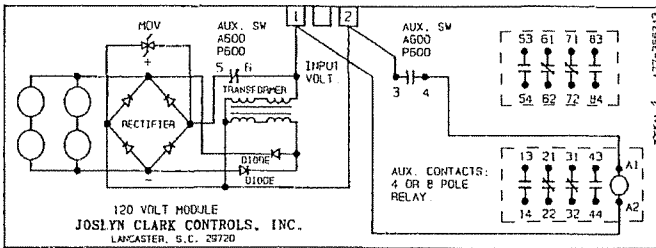

Fig 6

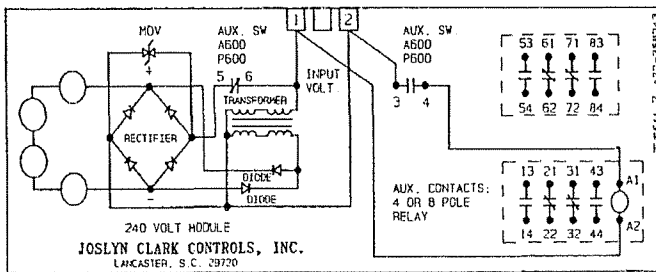

Fig 7

MAINTENANCE

DANGER

HAZARD OF ELECTRICAL SHOCK OR BURN

ALL POWER SHOULD BE DISCONNECTED FROM THE CONTROLLER EQUIPMENT PRIOR TO PERFORMING ANY TROUBLE SHOOTING OR MAINTENANCE WORK ON THE CONTACTOR. HOWEVER, THE EQUIPMENT HAS BEEN DESIGNED TO PERMIT MAINTENANCE AND/OR TESTING ON THE CONTACTOR AFTER IT HAS BEEN ISOLATED FROM THE MAIN POWER. WHEN PERFORMING THIS WORK, EXTREME CAUTION MUST BE EXERCISED IN VIEW OF THE PRESENCE OF HAZARDOUS VOLTAGE.

IT IS RECOMMENDED THAT CONTACTOR BE REMOVED FROM CONTROLLER SECTION FOR ADDITIONAL SAFETY AND EASE OF MAINTENANCE.

The contactor is designed for long life with minimal maintenance. The mechanical life is at least 750,000 and electrical life on normal motor switching is 600,000 at 200A, 400,000 at 400A & 250,000 at 600A . An operation is considered as one closed and one open operation.

The contactor requires no adjustments. Preventative maintenance is at least suggested to be done on a routine basis through a general inspection of the contactor every twelve months. This should involve mechanically operating the device for freedom of movement and a cleanliness check with regard to dust or other contaminants.

CLEANING

Clean all dirt from the contactor. Pay particular attention to molded parts and tracking surfaces. Foreign materials on these surfaces should be removed.

CONTACT WEAR

The contactor is equipped with a wear indicator and combined on off indicator. The on-off indicator measures total stroke. A narrow green bar will appear in the lens in the "OFF" position. Refer Fig. 8. The green area will be expanded as the contactor closes to its fully closed or total stroke movement, Fig. 9.

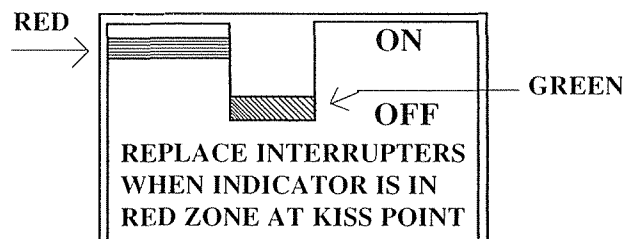

Fig. 8

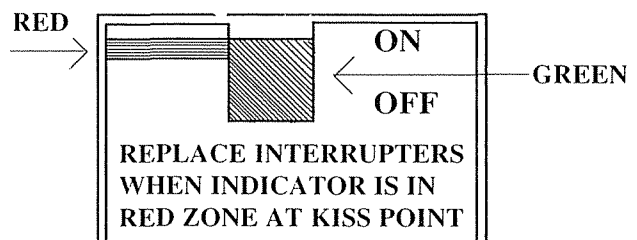

Fig 9

Test for contact wear.

DANGER
EXISTING CONTROL POWER WIRING MUST BE DISCONNECTED FROM TERMINALS 1 AND 2 TO PREVENT POSSIBLE FEEDBACK OF VOLTAGE TO CONTROL POWER TRANSFORMERS. FAILURE TO DO SO COULD LEAD TO EXPOSURE OF PERSONNEL TO POTENTIALLY HAZARDOUS VOLTAGES.

Contact wear is checked as follows if the contactor fails this test the interrupter must be changed refer interrupter replacement Fig. 12.

Connect continuity leads to line and load terminals of phase L1, with contactor de-energized, using 1/4 hexagon Allen Wrench on shaft, close contactor manually until continuity is made. The green bar "must not" be in the red zone, when continuity is made, refer Fig. 10 if it does electrical life is exhausted. Proceed to phase L2 phase L3 and repeat to complete the contactor test. If any test allows the indicator to fall in the "RED ZONE" before continuity is made then the interrupter being tested requires to be replaced.

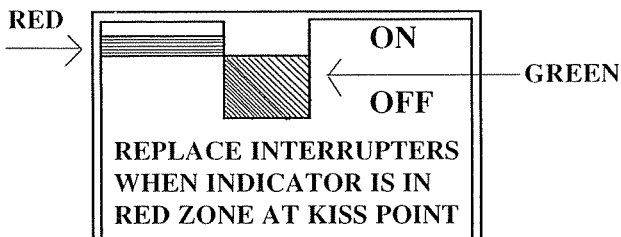

Fig. 10

NOTE

For contactors without ON/OFF indicators follow test procedure described above. using the movement of the Allen Key, (In the shaft). The key will move a total of 30° or 5 minutes of equivalent clock face movement. Continuity must be made before 24° or 4 minutes of clock face movement, otherwise electrical life is exhausted and the interrupter must be replaced. Contactors without ON/OFF indicators were of production vintage August 1990 - September 1991.

VACUUM INTERRUPTER INTEGRITY TEST

A high potential test will determine the dielectric condition and vacuum integrity for each vacuum interrupter.

CAUTION
A HIGH POTENTIAL TEST SHOULD BE PERFORMED ON EACH VACUUM INTERRUPTER IF THERE IS REASON TO SUSPECT VACUUM BOTTLE DAMAGE.

DANGER
EXERCISE CAUTION WHILE PERFORMING HIGH POTENTIAL TEST. HIGH VOLTAGES APPLIED ARE POTENTIALLY HAZARDOUS

The vacuum integrity test should be performed if contactor has been exposed to fault conditions. In addition, it is recommended that a vacuum integrity test be performed once a year as part of regular maintenance.

If contactor has been exposed to fault conditions, as indicated by blown fuses or tripped circuit breaker, the following checks must be made on the vacuum interrupter assemblies.

- Physical evidence of stress (distorted, discolored, or cracked bottles).
- Contact wear measurement (Refer to Contact Wear Measurement). Fig. 10
- Contact resistance.
- High Potential Test (Dielectric Test) If contactor is mounted in a controller, remove before performing inspections and tests.

CONTACT RESISTANCE

A contact resistance test can be performed using a micro-ohmmeter. This test determines the condition of contact tip surfaces.

With the contactor closed, the resistance across the terminals should be less than 200 micro-ohms. If higher contact resistance values are measured then the high potential test should be performed.

Before performing high potential test it is recommended you remove contactor from enclosure. The line and load power cables on each and control wires 1 and 2 on control terminal boards must be disconnected to avoid any possible feedback to upstream or downstream equipment.

DANGER
POSSIBILITY OF X-RAY EXPOSURE
DURING HI-POT TEST

PERSONNEL SHOULD BE NO CLOSER THAN 10 FEET AND PREFERABLY BEHIND A METAL BARRIER. TEST TIMES SHOULD BE KEPT TO A MINIMUM. THIS IS A PRECAUTION UNTIL SUCH TIME AS THE POSSIBLE HAZARD IS BETTER UNDERSTOOD AND STANDARDS ARE PUBLISHED.

HIGH POTENTIAL TEST (DIELECTRIC TEST)

The following test should be performed using a 50/60 Hertz test set, where the voltage is continuously variable up to at least 30KV R.M.S. X-radiation at this level is negligible, however, personnel should not be closer than 10 feet to the interrupter under test to avoid high voltage shock hazards. The contactor should be free of dust and other contaminants before conducting this test.

Connect output leads of test set across the interrupter terminals with the contactor in the OPEN position. **Slowly** raise the voltage from zero to Test Voltage and hold for 15 seconds. During voltage ramping any discharge or test tripping should be ignored unless it becomes impossible to reach Test Voltage. The leakage current should not exceed 5 milliamps during the test. Reverse the test set leads on interrupter terminals and repeat the test. If unit fails test, then phase assembly should be replaced (See Phase Assembly Replacement Instructions).

TEST VOLTAGE

Rating (KV)	Test KV Voltage
2.5	7.15
5.0	13.25
7.2	18.25

DISMANTLING

To remove control module, unscrew two cover screws, using 1/4 " box wrench remove bolt "B", Fig.11, the control module can then be removed. For assembly reverse this procedure, aligning the magnet plungers to slide into the brass sleeves that line the inner coil diameter. Make sure that brass sleeves are seated in upper magnet plate.

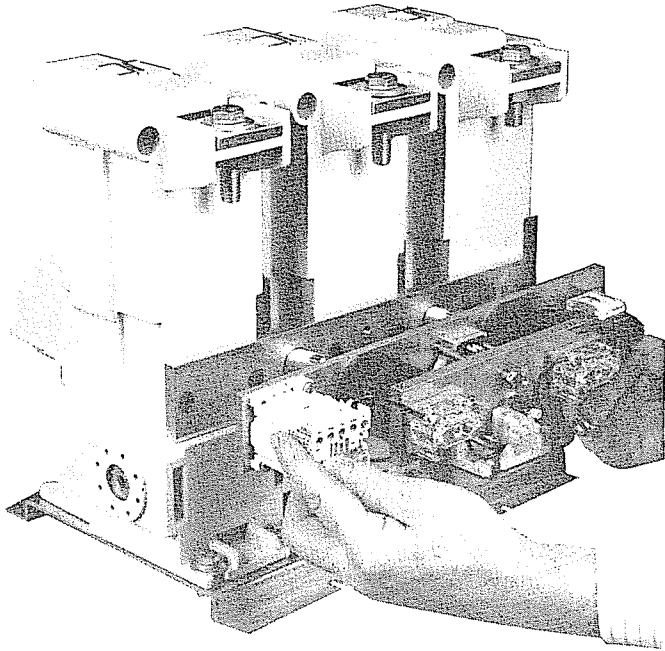

Fig. 11

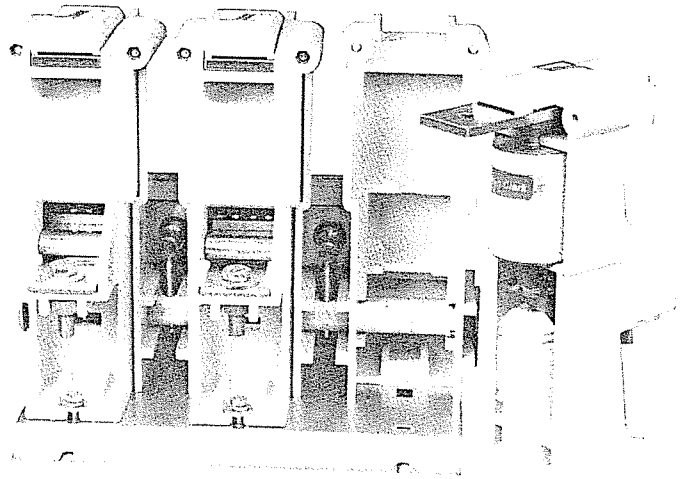

Fig. 12

INTERRUPTER REPLACEMENT (Fig. 12)

Remove line and load, cables, retain all hardware. Remove "JC" Logo molding "A" and retain screws. Using a box wrench remove two 1/4" bolts "B", retain hardware remove 5/16" bolt "C".

Half shell molding with interrupter will now slide out, replace with new unit reverse disassembly procedure to reassemble. Reuse original hardware re-torque line and load connections to 275 in-lbs.

Contactor Parts		200A	400A	600A	1100A
Description	Part#	Quantity	Quantity	Quantity	Quantity
200A Phase Assy	A77-356249A-1	1			
400A Phase Assy	A77-356249A-2		1		
600A Phase Assy	A77-356349A-3			1	2
* 120V Control Module	A77-356277A-1	1	1	1	2

NOTE: Double quantities for mechanical interlocked arrangements.

* When 240 V Control Module used Part # is A77 356277A-2