



INSTRUCTIONS FOR TRANQUELL®

POLYMER ARRESTERS

DISTRIBUTION MODELS 9L23, 3-30KV

RISER POLE MODELS 9L27, 3-30 KV

CAUTION: THE EQUIPMENT COVERED BY THESE INSTRUCTIONS SHOULD BE INSTALLED AND SERVICED ONLY BY COMPETENT PERSONNEL FAMILIAR WITH GOOD SAFETY PRACTICES. THIS INSTRUCTION IS WRITTEN FOR SUCH PERSONNEL AND IS NOT INTENDED AS A SUBSTITUTE FOR ADEQUATE TRAINING AND EXPERIENCE IN SAFE PROCEDURES FOR THIS TYPE OF EQUIPMENT.

WARNING: ARRESTERS APPLIED AT VOLTAGES HIGHER THAN RATING MAY CAUSE DAMAGE AND/OR INJURY. CHECK THE ARRESTER RATING, MARKED CLEARLY ON THE INTEGRAL BRACKET, TO ASSURE CORRECT APPLICATION.

INTRODUCTION

The TRANQUELL polymer distribution/riser pole arrester is designed to limit surge voltage by conducting the surge current to ground, and thus avoiding equipment damage. The arrester is of single pole design, suitable for outdoor use, and designed in accordance with the latest revision of the ANSI/IEEE C62.11 standard. The TRANQUELL arrester consists of a stack of MOV disks which are permanently sealed in a watertight polymer housing. The arrester is shipped fully assembled. For drawings and dimensions of the XEP full line of arresters refer to Figs. 1,2,3 and 4.

CONTINUOUS OPERATING VOLTAGE

TRANQUELL arresters must be applied where the continuous phase-to-ground power frequency voltage at the arrester location does not exceed the arrester continuous voltage capability as indicated on the nameplate. In case of doubt concerning application, consult your local GE company representative.

ALTITUDE AND TEMPERATURE

The 9L23 and 9L27 series arresters can be used from 0-12,000 feet (3600m) altitude. These arresters can be used in locations where the maximum temperature does not exceed 60° C and where the weighted average temperature does not exceed 45° C.

INITIAL INSPECTION

Although it is very unlikely, extraordinarily rough handling can result in damage to the TRANQUELL polymer arrester. Careful inspection of each arrester prior to installation is required to assure that no damage has occurred during shipment. *If damage is apparent, do not install arrester.* Claims for shipping damage should be registered immediately with the common carrier.

The model number, rating, and maximum continuous operating voltage (MCOV) are identified on the nameplate which is imprinted on the top metal end plate. The nameplate information should be checked against the shipping memorandum. If at any time it is

necessary to correspond with the GE company, complete nameplate data should be furnished in order to expedite replies.

INSTALLATION

Install the arrester electrically as close as practicable to the equipment to be protected. Keep the arrester connections short and direct. Connect the arrester ground to the equipment ground, and the line connection should be made in such a manner that no excessive mechanical stress is placed on the arrester. Additionally, no more than 20 ft.-lb. of torque should be applied while tightening down any nuts.

CAUTION: Always be certain that the ground connection is firmly made before connecting the arrester to the line.

REMOVAL

When a metal-oxide arrester is disconnected from an energized line, it is possible for a small amount of static charge to be retained by the arrester. The energy available in the form of retained charge on the TRANQUELL polymer arresters is imperceptibly small. After disconnecting the arrester from the line, a slight "pin-prick" type spark may be felt by anyone touching the line end. As a precautionary measure, install a temporary ground on the line end of the arrester after it is disconnected from the line. This will ensure that any retained charge is discharged to ground. Remove the temporary ground before the arrester is re-installed.

WARNING: To avoid electrical shock when removing an arrester from service, consider it to be fully energized until both the line and ground leads are disconnected.

ARRESTER CARE

TRANQUELL polymer arresters do not require special care. These arresters do not require testing, and no test which applies power voltage in excess of maximum arrester voltage rating should be made without consulting the GE Company. Additionally, there is no single field test which will indicate the complete operating characteristics of the arrester.

These instructions do not purport to cover all details or variations in equipment nor to provide for every possible contingency to be met in connection with installation operation or maintenance. Should further information be desired or should particular problems arise which are not covered sufficiently for the purchaser's purposes, the matter should be referred to the GE Company.



GE Transmission Systems

GE Company
381 Broadway
Fort Edward, NY 12828-1000

GEH - 5972E TRANQUELL® POLYMER DISTRIBUTION/RISER POLE ARRESTERS

NOTES

1. These arresters are for 0 to 12,000 ft. (0 to 3600m) altitude. For special arresters involving high altitudes, other combinations of hardware, etc., refer to the nearest GE sales office.
 2. Basic unit model number does not include mounting hardware or accessories.

3. All polymer containers are gray color.
 4. Dimensions outside brackets (..) are in inches; dimensions within brackets are in millimeters.
 5. Line and ground connectors can accommodate Al/Cu conductors up to 5/16 inch diameter solid or No. 2 cable, 7 strands.

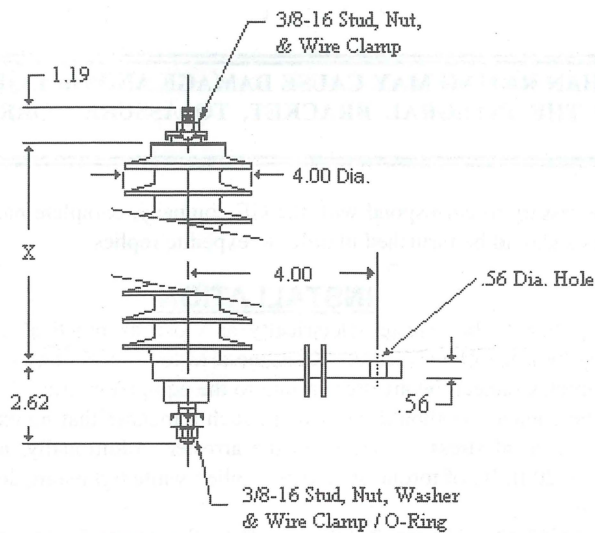

**Fig. 1, Heavy Duty Distribution Arrester
3 kV through 10 kV**

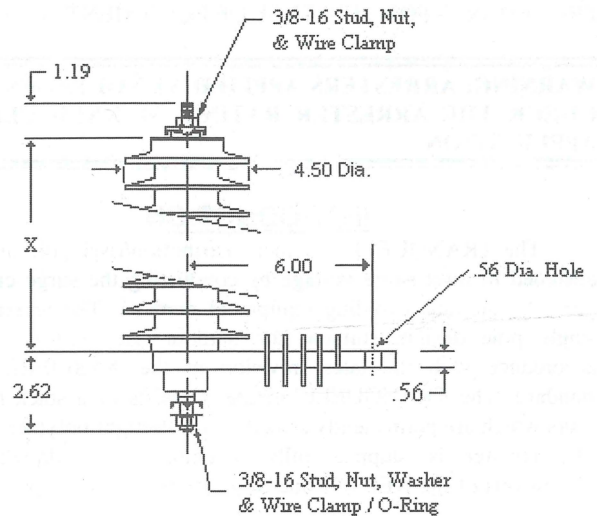

**Fig. 2, Heavy Duty Distribution Arrester
12 kV through 36 kV**

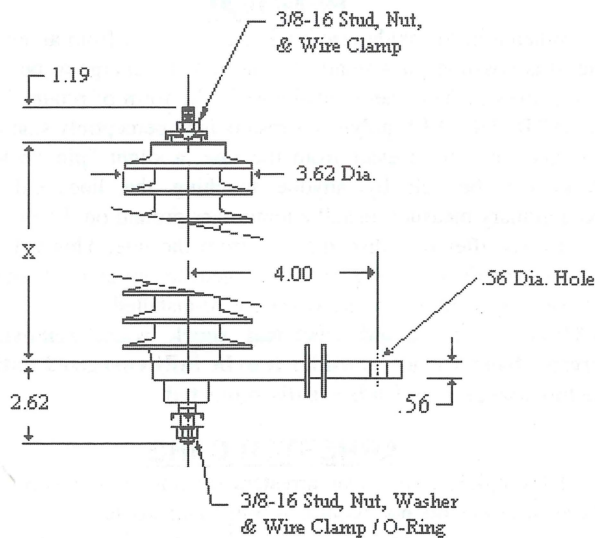

**Fig. 3, Riser Pole Arrester
3 kV through 10 kV**

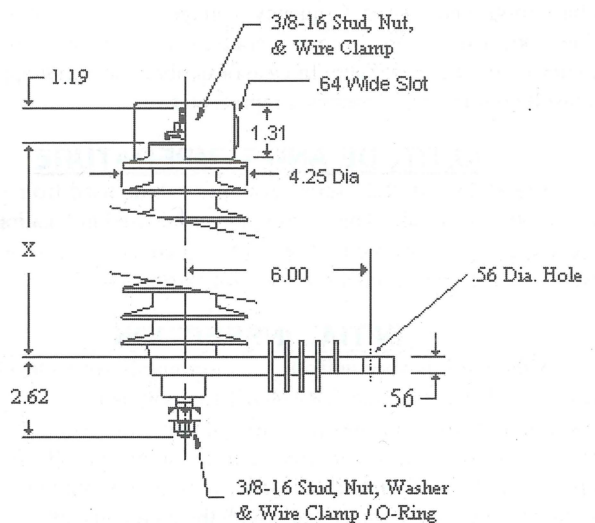

**Fig. 4, Riser Pole Arrester
12 kV through 36 kV**

Provided by Northeast Power Systems, Inc.
www.nepsi.com



GE Transmission Systems

GE Company
381 Broadway
Fort Edward, NY 12828-1000



INSTRUCTIONS FOR TRANQUELL® XEP™

POLYMER ARRESTERS

STATION MODELS 9L11XP

INTERMEDIATE MODELS 9L12PP

CAUTION: THE EQUIPMENT COVERED BY THESE INSTRUCTIONS SHOULD BE INSTALLED AND SERVICED ONLY BY COMPETENT PERSONNEL FAMILIAR WITH GOOD SAFETY PRACTICES. THIS INSTRUCTION IS WRITTEN FOR SUCH PERSONNEL AND IS NOT INTENDED AS A SUBSTITUTE FOR ADEQUATE TRAINING AND EXPERIENCE IN SAFE PROCEDURES FOR THIS TYPE OF EQUIPMENT.

WARNING: ARRESTERS APPLIED AT VOLTAGES HIGHER THAN RATING MAY CAUSE DAMAGE AND/OR INJURY. CHECK THE ARRESTER RATING, MARKED CLEARLY ON THE NAMEPLATE, TO ASSURE CORRECT APPLICATION.

INTRODUCTION

The TRANQUELL XEP polymer station/intermediate arrester is designed to limit surge voltage by conducting the surge current to ground, and thus avoiding equipment damage. The arrester is of single pole design, suitable for outdoor use, and designed in accordance with the latest revision of the ANSI/IEEE C62.11 standard. Three arresters are required for three-phase installation.

The TRANQUELL XEP arrester consists of a stack of ZENOX™ disks which are permanently sealed in a watertight polymer housing. The arrester is shipped fully assembled. A metal end fitting provides a means for bolting the arrester to a foundation. An outline drawing is included with every arrester and should be reviewed for details.

CONTINUOUS OPERATING VOLTAGE

TRANQUELL XEP arresters must be applied where the continuous phase-to-ground power frequency voltage at the arrester location does not exceed the arrester continuous voltage capability as indicated on the nameplate. In case of doubt concerning application, consult your local GE company representative.

ALTITUDE AND TEMPERATURE

The 9L11 and 9L12 series arresters can be used from 0-10,000 feet (3050m) altitude. These arresters can be used in

locations where the maximum temperature does not exceed 60° C and where the weighted average temperature does not exceed 40° C.

INITIAL INSPECTION

Although it is very unlikely, extraordinarily rough handling can result in damage to the TRANQUELL XEP polymer arrester. Careful inspection of each arrester prior to installation is required to assure that no damage has occurred during shipment. *If damage is apparent, do not install arrester.* Claims for shipping damage should be registered immediately with the common carrier.

The model number, rating, and maximum continuous operating voltage (MCOV) are identified on the nameplate. The nameplate information should be checked against the shipping memorandum. If at any time it is necessary to correspond with the GE company, complete nameplate data should be furnished in order to expedite replies.

INSTALLATION

LOCATION

Install the arrester electrically as close as practicable to the equipment to be protected. Keep the arrester connections short and direct. The footings of all outdoor piers or supports should extend below the frost line and be elevated above the ground line sufficiently to meet personnel safety requirements.

These instructions do not purport to cover all details or variations in equipment nor to provide for every possible contingency to be met in connection with installation operation or maintenance. Should further information be desired or should particular problems arise which are not covered sufficiently for the purchaser's purposes, the matter should be referred to the GE Company.



GE Transmission Systems

GE Company
381 Broadway
Fort Edward, NY 12828-1000

CLEARANCE

The term "clearance" means the actual distance between any parts of the arrester at line potential and any object at ground potential or other phase potential. Clearances listed on the appropriate outline print packed with each arrester are the minimum recommended and were determined such that the operation and capability of the arrester is not significantly affected. These clearances apply for conventional outdoor substations. These values should be used only after it has been determined that any local codes or standard practices do not require larger clearances. The values shown are suitable for altitudes up to 3300 feet (1000 meters). At higher altitudes, add 3 percent for each additional 1000 feet of elevation. The arrangement of the foundation plans if shown on the outlines can be modified if proper clearances are maintained.

MOUNTING

Each arrester is shipped completely assembled. Install the arrester vertically on the foundation, using care to see that it is perpendicular, shimming under all but one foot if necessary. It is important that all feet rest solidly on the foundation before the foundation bolts are drawn down to avoid unnecessary stresses in the end fittings. Tighten the bolts firmly.

LINE AND GROUND CONNECTIONS

Connect the arrester ground to the apparatus ground and the main station ground, utilizing a reliable common ground network of low resistance. Connection to the line should be made through a suitable line connector. Line connections should be made in such a manner that no excessive mechanical stress is placed on the arrester. No more than 25 ft.-lbs. of torque should be applied while tightening down any nuts.

CAUTION: ALWAYS BE CERTAIN THAT THE GROUND CONNECTION IS FIRMLY MADE BEFORE CONNECTING THE ARRESTER TO AN ENERGIZED LINE. IF AN INSULATING UNIT IS USED AT THE GROUND END TO PERMIT USE OF A DISCHARGE COUNTER, THE DISCHARGE COUNTER MUST BE CONNECTED (OR THE INSULATING UNIT SHORTED OUT) BEFORE CONNECTING THE ARRESTER TO AN ENERGIZED LINE.

PERIODIC INSPECTION, MAINTENANCE AND REMOVAL

Before inspecting or handling, disconnect the arrester from the line. When a metal-oxide arrester is disconnected from an energized line, it is possible for a small amount of static charge to be retained by the arrester. The energy available in the form of retained charge on the TRANQUELL XEP polymer arresters is imperceptibly small. After disconnecting the arrester from the line, a slight "pin-prick" type spark may be felt by anyone touching the line end. As a precautionary measure, install a temporary ground on the line end of the arrester after it is disconnected from the line. This will ensure that any retained charge is discharged to ground. *Remove the temporary ground before the arrester is re-installed.*

TRANQUELL arresters require no special care. They may be hot-washed, subject to the usual care and techniques used in hot-washing insulation to avoid external flashover.

These arresters do not require testing, and no test which applies power voltage in excess of maximum arrester voltage rating should be made without consulting the GE Company. There is no single field test which will indicate the complete operating characteristics of the arrester.

WARNING: To avoid electrical shock when removing an arrester from service, consider it to be fully energized until both the line and ground leads are disconnected.

STORAGE

As all TRANQUELL XEP arresters are designed for outdoor use, they may be stored outdoors if suitable precautions are taken to prevent deterioration of the packing material. The arresters may be covered with a polyethylene or other waterproof covering to keep them dry, clean, and free from litter until used. In climates where outdoor temperature and humidity extremes rapidly deteriorate the cardboard packing material, it is recommended that arresters to be stored outdoors be removed from their packing and be bolted (vertically) to a skid.

DISCHARGE COUNTERS

An insulating base is required when installing a discharge counter with arresters. Both of these are accessories and are available through your local GE Sales Office. Install the discharge counter and insulating bases as shown on the outline drawing furnished with the counter.



GE Transmission Systems

GE Company
381 Broadway
Fort Edward, NY 12828-1000